

CHIP TRIMMER POTENTIOMETER

APPLICATION MANUAL



Murata
Manufacturing Co., Ltd.

Contents

1	Features and Specifications	2
	1. Features of Murata Chip Trimmer Potentiometers	2
	2. Specifications	4
2	Storage	5
	1. Precautions in Storage	5
3	Design of Printed Circuit Boards	6
	1. Considerations in Design	6
	2. Standard Land Patterns	6
4	Typical Chip Mounting Processes	9
	1. One Side Chip Mounting	9
	2. Both Side Chip Mounting	9
	3. Mixed Mounting of Chip Components and Leaded Components	9
5	Chip Mounting Process	10
	1. Solder Paste Stenciling	10
	2. Mounting the Product	10
	3. Compatibility with Chip Placers	11
	4. Sensor Level Adjustment	12
	5. Reflow Soldering	12
	6. Adhesive Application and Curing	13
	—Types and Characteristics of Adhesive—	
	7. Flux Coating	14
	—Types and Characteristics of Flux—	
	8. Wave Soldering	15
	9. Soldering and Resoldering with a Soldering Iron	15
	10. Cleaning	16
6	Adjustments and Lock Painting	17
	1. Adjustments	17
	2. Automatic Adjustments	18
	3. Lock Painting	19
7	Examples of Improper Application and Prevention of the Troubles	20
	Ex.1. Poor Contact Caused by Flux Adhesion	20
	Ex.2. Cracking of the Substrate	21
	Ex.3. Poor Contact Caused by a Deformed Driver Plate	21

1 Features and Specifications

1. Features of Murata Chip Trimmer Potentiometers

Murata supplies various types of chip trimmer potentiometers which are designed for various purposes.

POZ3 Series

This series is designed for automatic resistance adjustments. Manual adjustments are also possible and its handling is easy.

Since metal plate terminals are employed, the possibility of solder leaching is eliminated and virtually no peeling-off of electrodes occurs even if the PCB warps. Its gold plating ensures high solderability.

The POZ3KN series has a flat surface to facilitate pick-up by a chip placer.

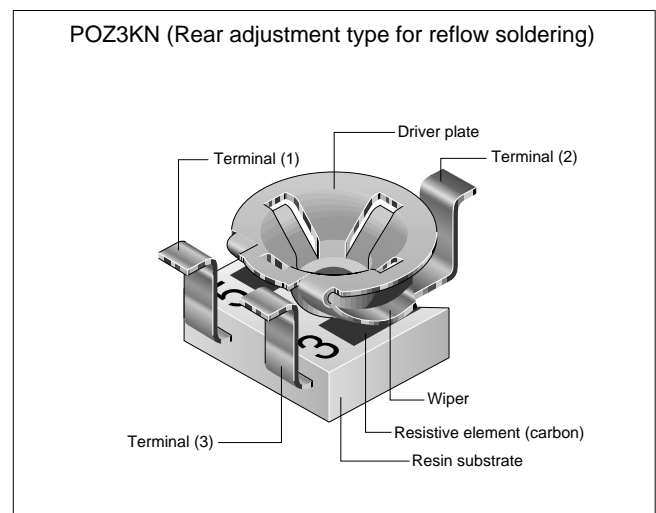
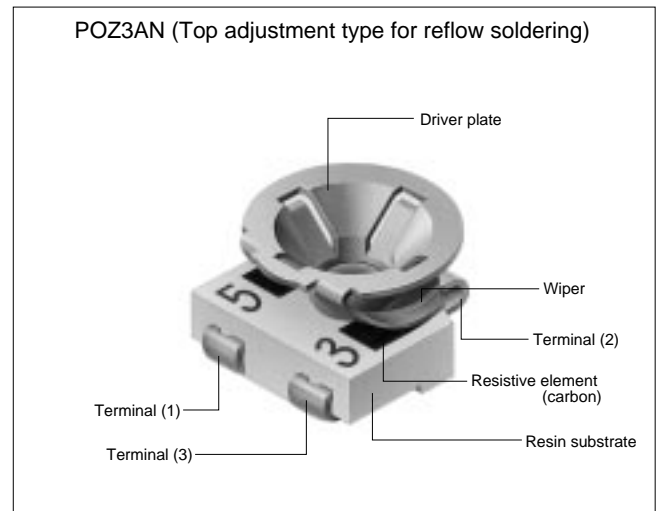

RVG3 Series

This series is designed for automatic resistance adjustments. Manual adjustments are also possible and its handling is easy.

The plated electrodes prevent solder leaching.

The RVG3S08 series is provided with a stopper to prevent the driver plate from turning beyond the electrically effective range (or to prevent the wiper from becoming electrically open).

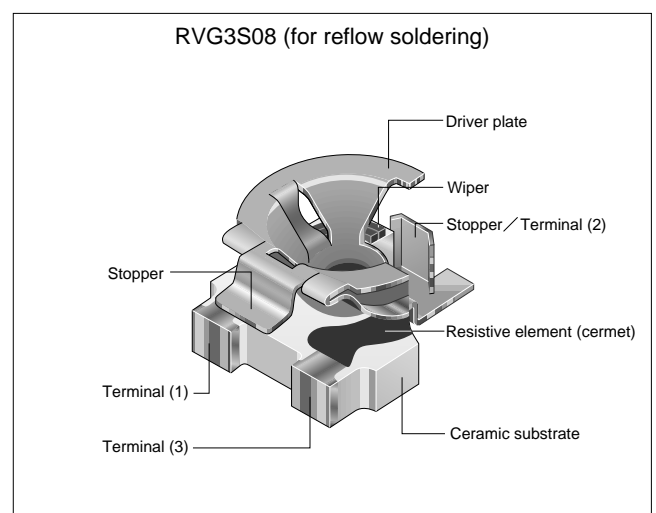

Features and Specifications **1**

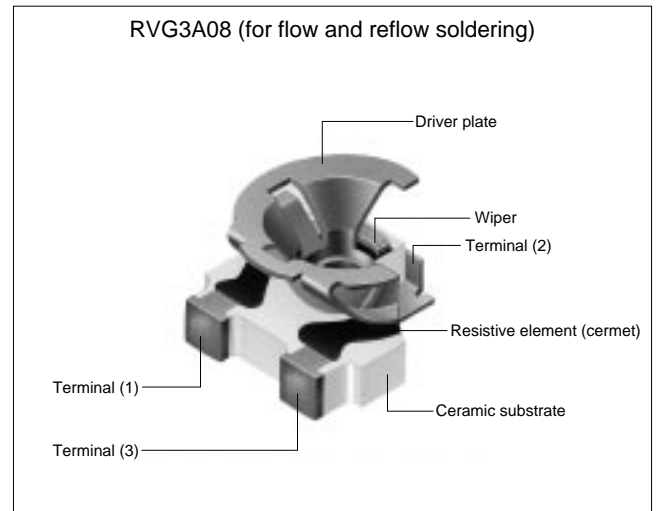

RVG4M Series

The electrodes are plated to minimize solder leaching. Since the structure is hermetically sealed, flux cleaning (removal) after soldering is not necessary. Resin coating after adjustment is possible.

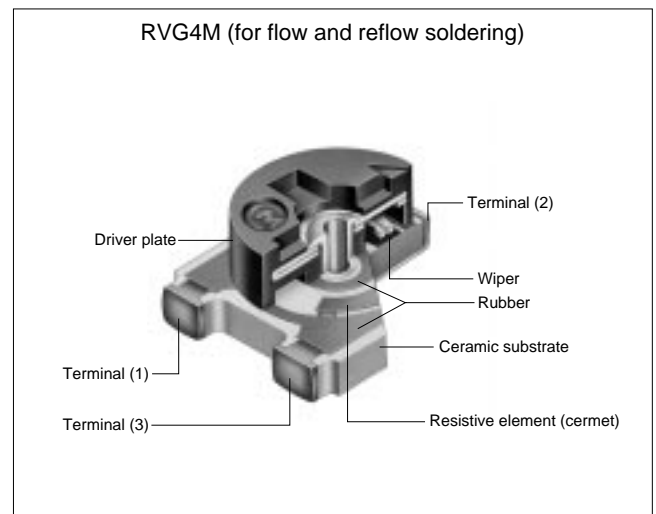

POG5 Series

Since metal plate terminals are employed, the possibility of solder leaching is eliminated and virtually no peeling-off of electrodes occurs even if the PCB warps. Since the structure is hermetically sealed, flux cleaning (removal) after soldering is not necessary. Resin coating after adjustment is possible. It features compactness and provides high resolution with 11 turns. It is easy to make fine adjustments.

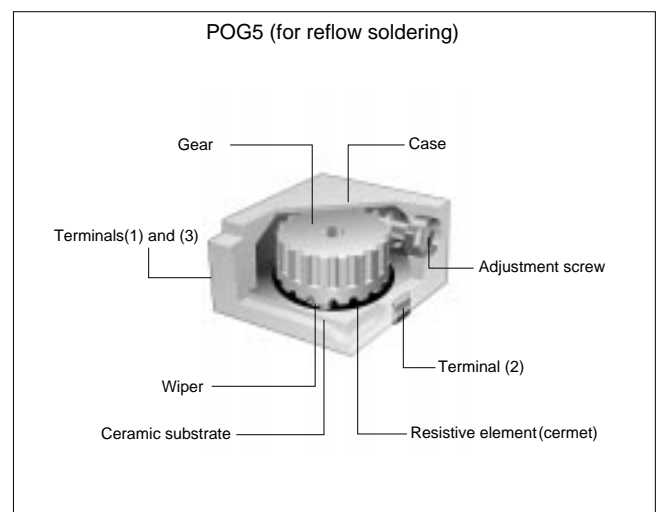

1 Features and Specifications

2. Specifications

Item		Series		POZ3 Series		RVG3 Series		RVG4M Series		POG5 Series	
				POZ3AN	POZ3KN	RVG3S08	RVG3A08	RVG4M08	RVG4M58	POG5AN	POG5HN
Resistive element material	Cermet			●	●	●	●	●	●	●	●
	Carbon	●	●								
Terminal layout	Triangular	●	●	●	●	●	●	●	●	●	●
No. of terminals	3 (divider type)*1	●	●	●	●	●	●	●	●	●	●
Adjustment method	Automatic	●	●	●	●						
	Manual	●	●	●	●	●	●	●	●	●	●
Soldering	Reflow soldering	●	●	●	●	●	●	●	●	●	●
	Flow soldering				●	●	●				
Electrode surface treatment	Gold plating(nickel undercoating)	●	●								
	Solder plating (nickel undercoating)			● *3	● *3	● *3	● *3				
	Solder plating (copper undercoating)							●	●		
Size	3 mm square	●	●	●	●						
	4 mm square					●	●				
	5 mm square	●	●	●				●	●		
Product thickness	1.50mm			●							
	1.85mm	●			●						
	2.00mm					●	●				
	2.10mm		●								
	3.70mm										●
	5.00mm								●		
Product weight	0.040g(40mg)	●	●	●	●						
	0.080g(80mg)					●	●				
	0.180g(180mg)							●	●		
Cleaning	Necessary *2	●	●	●	●						
	Not necessary					●	●	●	●		
Lock painting	Possible					●	●	●	●		
	Not possible	●	●	●	●						
Taping packaging (reel with a diameter of 180 mm)	250 pcs./reel							●			
	500 pcs./reel					●	●			●	
	1500 pcs./reel		●								
	2000 pcs./reel	●			●						
	2500 pcs./reel			●							

*1 (1)---(2)---(3) They can be used as the rheostat type by connecting lands (2) and (3). (2 terminals (rheostat type) (1)---(2))

*2 Cleaning is needed only when there is an adhesion of foreign matter such as flux on the resistive element.

*3 Only terminal (2) is gold-plated with a nickel undercoat.

2 Storage

1. Precautions in Storage

To ensure the solderability of the terminals, Murata chip trimmer potentiometers are plated as shown in the table on the right. However, if they should be stored in a hot, humid atmosphere or in an atmosphere which is contaminated with sulfur or chlorine gas, the external surfaces of the terminals might be oxidized or sulfated, causing a deterioration in solderability.

To prevent this, the following storage conditions should be met.

Storage Environment

Make sure that the ambient temperature is below 40°C and the relative humidity is below 70%RH. The atmosphere should not contain sulfur and chlorine gases.

Storage Method

Don't open the minimum package until just before use. After the package is opened, it should be sealed again by heating or stored in a desiccator. (When resealing the package, never use a rubber band.)

Storage Period

Stored products should be used within six months. If you are going to use a product which has been stored for more than six months, check its solderability beforehand.

■Electrode Surface Treatment

Series	Electrode surface treatment
POZ3	Gold plating (nickel undercoating)
RVG3 RVG4M	Terminals (1) & (3): Solder plating (nickel undercoating) Terminal (2) : Gold plating (nickel undercoating)
POG5	Solder plating (copper undercoating)

3 Design of Printed Circuit Boards

1. Considerations in Design

To mount chip trimmer potentiometers on a PCB, it is necessary to design land patterns. In designing land patterns, take the following points into consideration.

Land Pattern Area

If the land pattern area is too large, a positional error can easily occur due to the solder's surface tension. If the area is too small, the required solder adhesive strength will not be obtained. To prevent this type of trouble, please use our standard land patterns.

Both Side Chip Mounting

If the mounting process includes reflow soldering for the upper side of the PCB and flow soldering for its lower side and a product is mounted on the upper side by reflow soldering without cleaning, take the following cautions in order to prevent the flux from flowing onto the wiper sliding surface:

- ① Don't place the product within 10 mm from the outer edge of the PCB.
- ② Don't provide a through hole near the product. (A distance of 10 mm or more between the product and a through hole is necessary.)

Other Considerations

- ① Self-alignment
- ② Solder adhesive strength

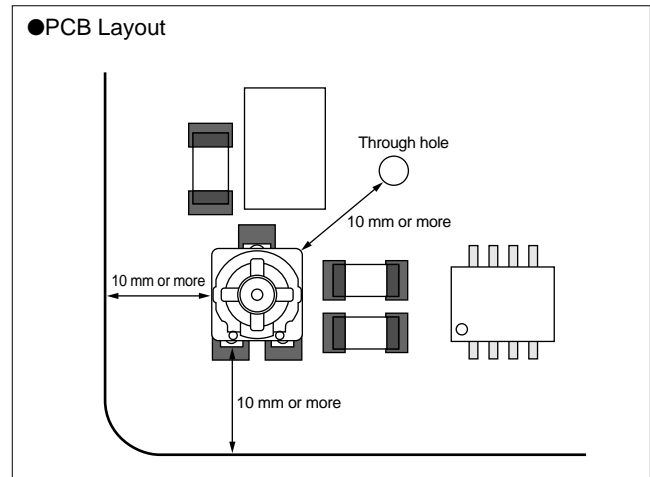

2. Standard Land Patterns

POZ3AN

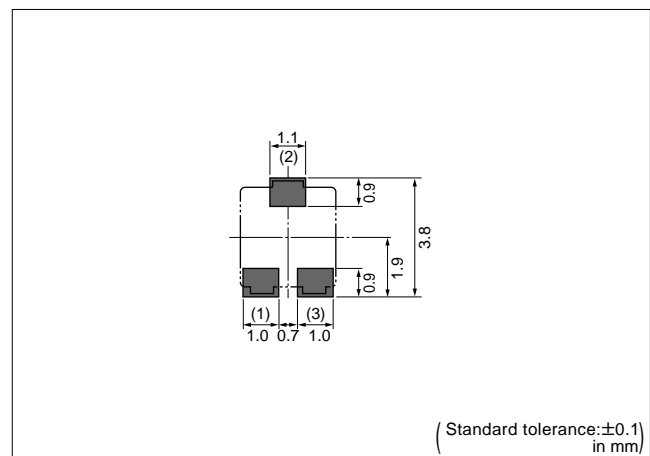
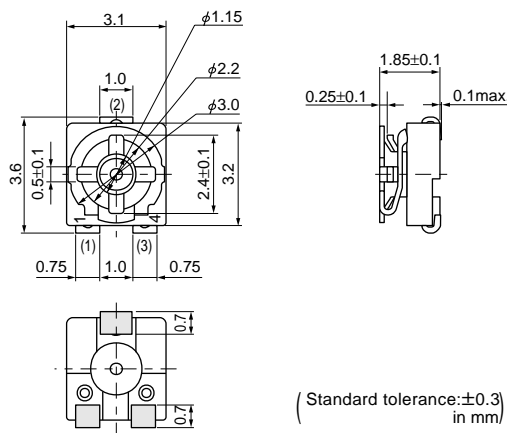

Design of Printed Circuit Boards 3

POZ3KN

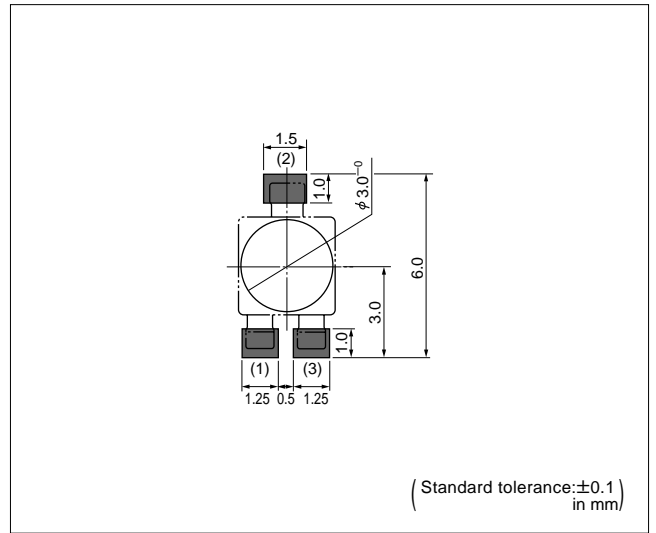
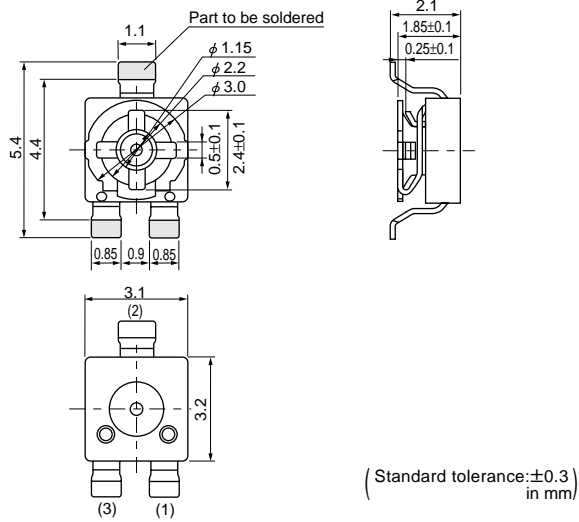

RVG3S08

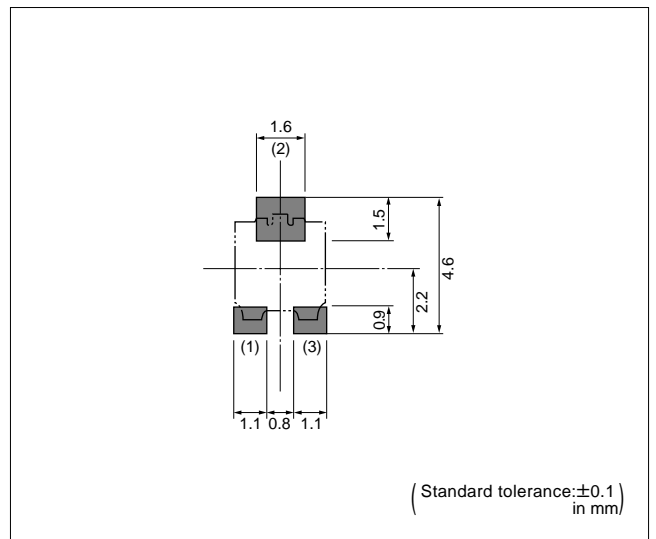
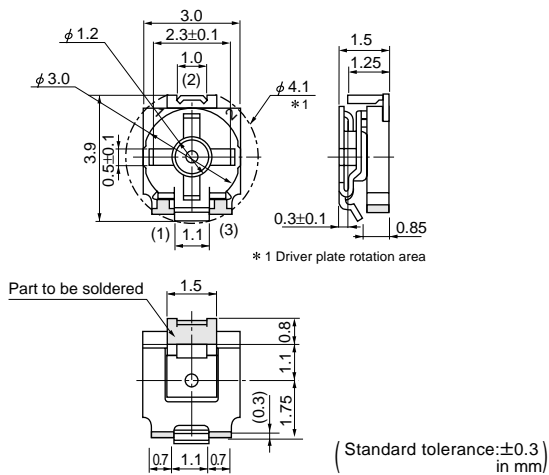

RVG3A08

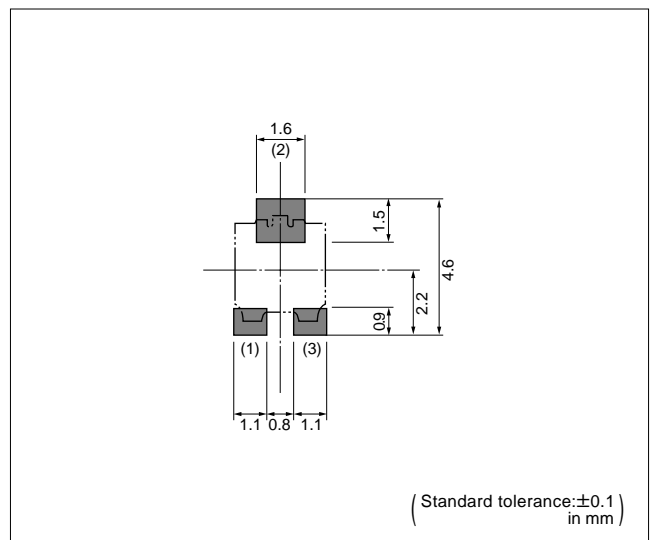
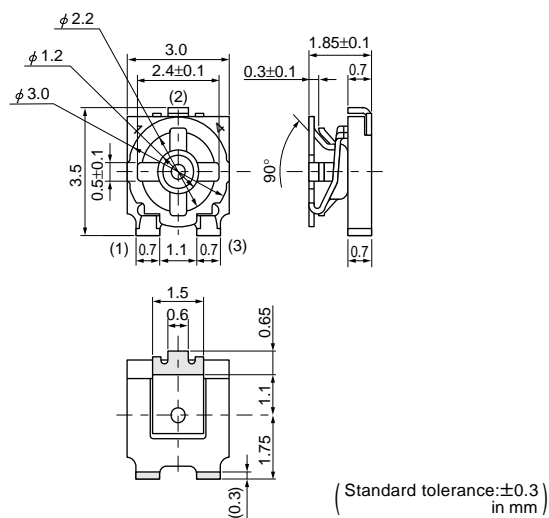

3 Design of Printed Circuit Boards

RVG4M08/58

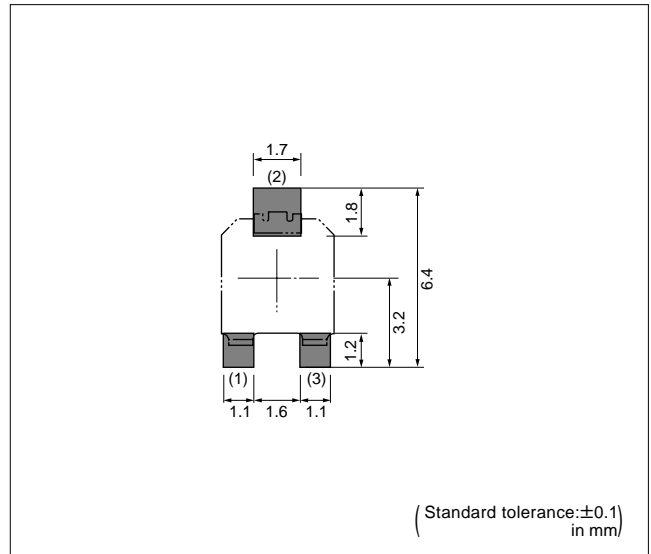
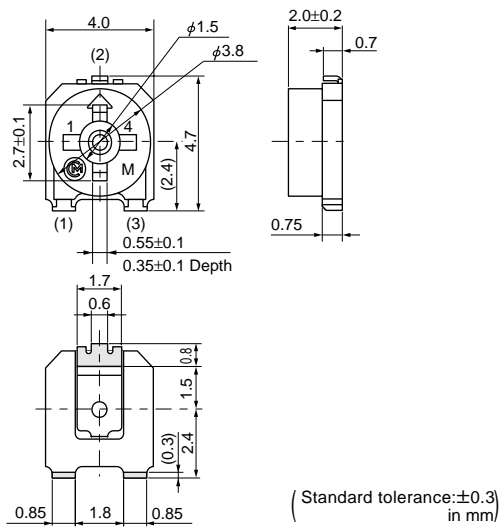

POG5ANtype

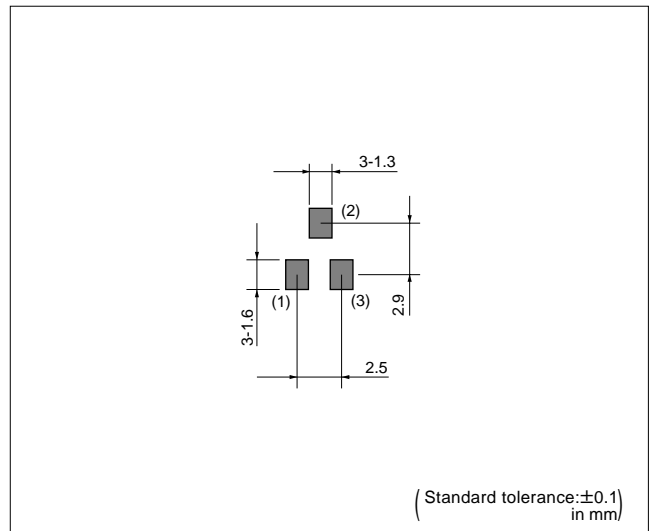
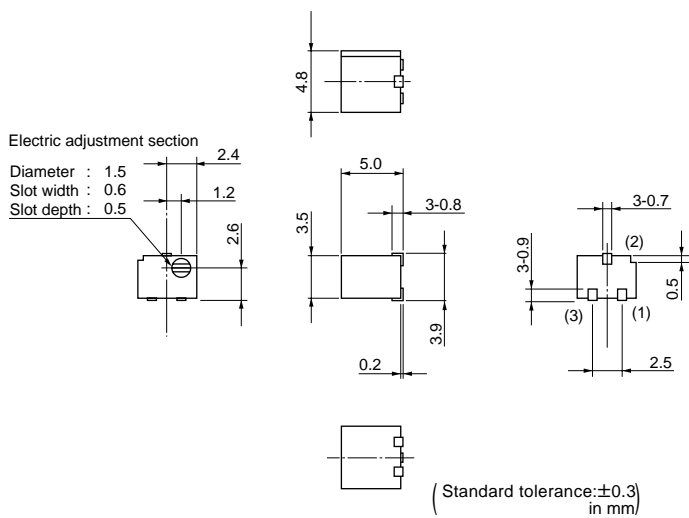

POG5HNtype

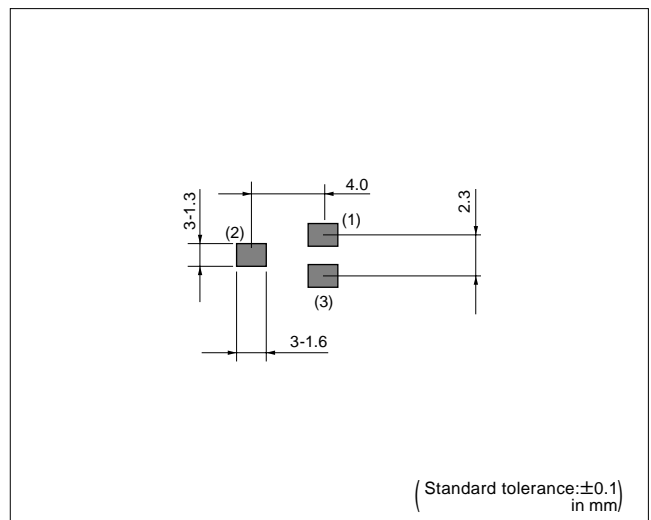
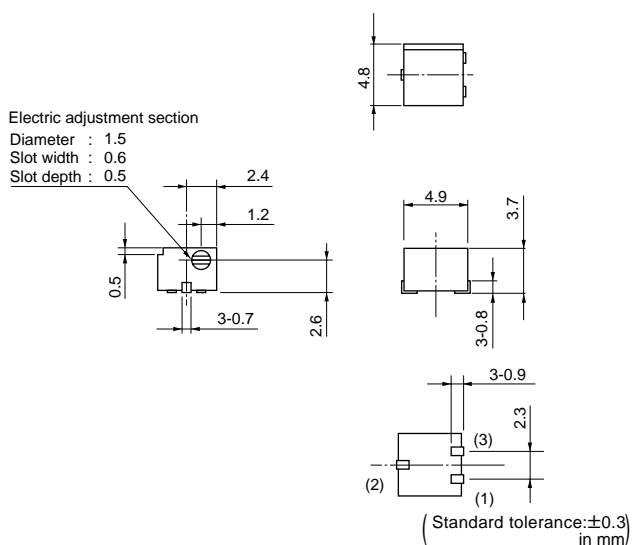

4 Typical Chip Mounting Processes

Typical chip mounting processes as listed below are available.
 It should be noted that the mounting procedures, soldering method and standard land pattern vary depending on the process employed.

1. One Side Chip Mounting

Reflow Soldering System

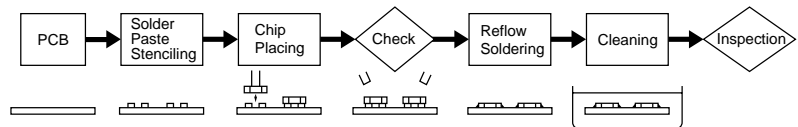

Flow Soldering System

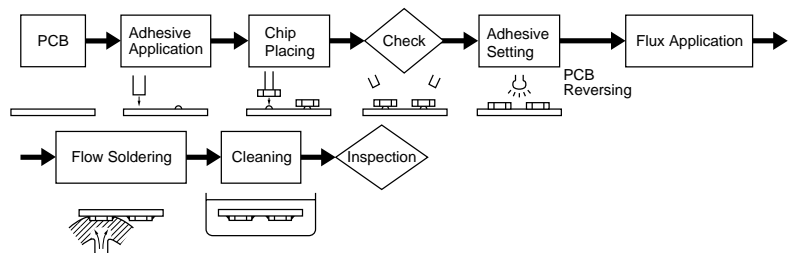

2. Both Side Chip Mounting

One Side Reflow/ One Side Flow System

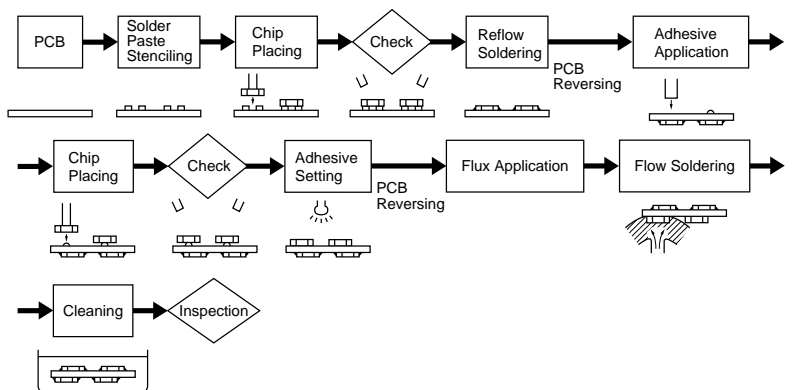

Both Side Reflow System

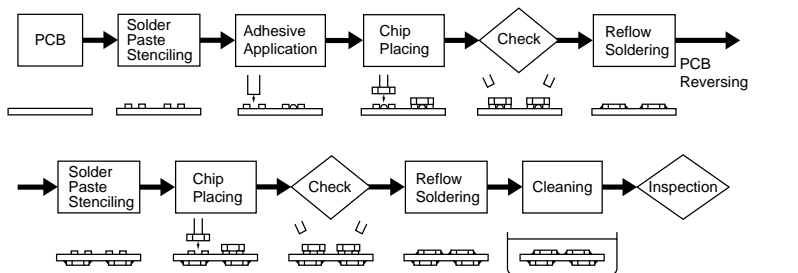

3. Mixed Mounting of Chip Components and Leaded Components

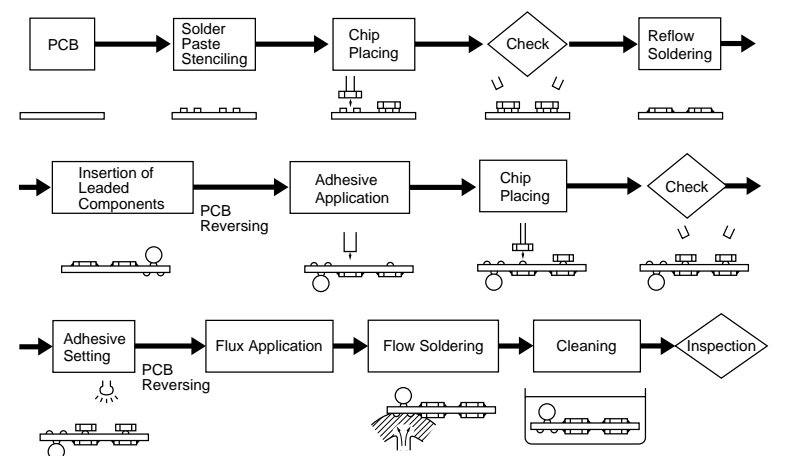

5 Chip Mounting Process

1. Solder Paste Stenciling

The Amount of Solder Paste

According to the figure on the right, apply the appropriate amount of solder paste with a stencil so that the solder covers the side face of the electrode. If the amount of solder paste applied to the land is insufficient, the required adhesive strength cannot be obtained. If an excessive amount of solder paste is applied, solder bridging or flux overflow to the resistive element surface can occur. Standard thicknesses of solder coating are listed in the table on the right.

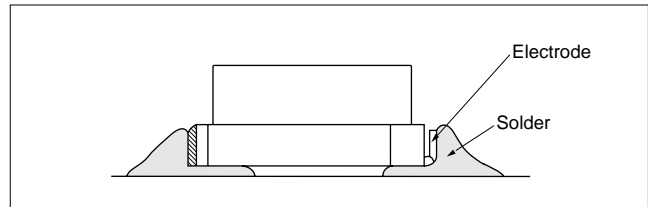

Series	Standard applying thickness
POZ3AN, RVG3A, RVG4M, POG5	150—200 μ m
POZ3KN	100—150 μ m

2. Mounting the Product

When mounting the product, pay attention to the following points.

Dimensions of the Positioning Claws

In chip placers which mechanically determine the pick-up position, check the dimensions of the positioning claws, referring to the figure on the right. The width of each claw should be such that it cannot be inside the space between terminals (1) and (3). If it is inside the space between them, the product may get out of place or air leakage may occur.

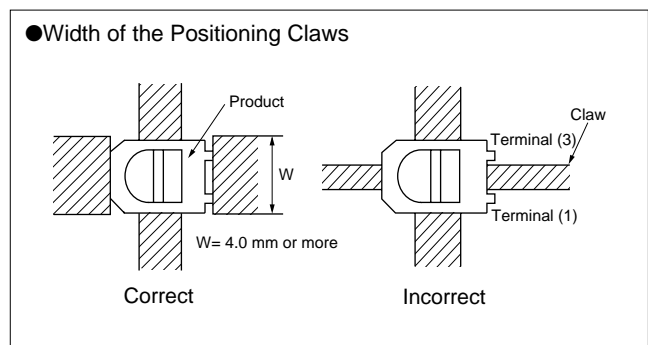
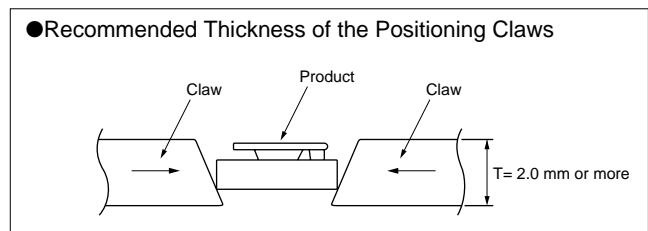

Dimensions of the Pick-up Nozzle

The size of the pick-up nozzle should fit the suction surface of each product. There are two nozzle types as shown on the right in the figure. Use the suitable type for each series as indicated here.

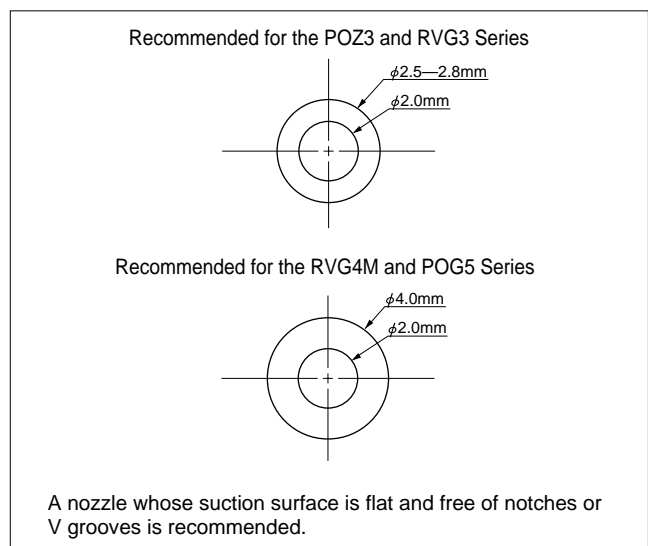

Pressure

The pressure from the pick-up nozzle should be 100 gf to 300 gf of static load.

Chip Mounting Process **5**

Adjustment of the Pick-up Nozzle Bottom Dead Point

If the bottom dead point of the pick-up nozzle is too low, an excessive force would be applied to the product, causing a decrease in torque, deformation of the driver plate or a crack in the PCB. Also, if dust is collected in the gap between the pick-up nozzle and cylinder inner wall, the nozzle would fail to move smoothly and thus cause an excessive force to be applied to the product, resulting in a similar type of trouble.

Precautions in Mounting the Product

In the POZ3, RVG3 and RVG4M series, some air leak will inevitably occur during pick-up. Therefore, if the chip placer is equipped with a vacuum sensor system, the acceptance level for air leaks as judgment criteria must be adjusted beforehand. Unless this adjustment is made properly, the chip placer might fail to function. (For the adjusting procedure, see "4. Sensor Level Adjustment".)

For the POZ3KN series, use a chip placer which incorporates an image processing system to prevent deformation of terminals. (See the next paragraph, "Compatibility with Chip Placers".)

3. Compatibility with Chip Placers

When Using Commercial Chip Placers

The table on the right shows detection methods for pick-up nozzle positioning which are employed by typical commercial chip placers.

When a chip placer of Group A or B as listed in the table is used to mount the product, sensor level (judgment criteria) adjustment is necessary.

For the Pulsar 100 series of Group A, removal of the nozzle clogging detection circuit is needed. For further information, please consult the manufacturer of the chip placer.

For chip placers of Group C or D, sensor level adjustment is unnecessary. If you are going to use a chip placer of Group D for the POZ3 and RVG3A08 series, please consult us.

For the sensor level adjusting procedure, see the next paragraph, "4. Sensor Level Adjustment".

Position Detection Methods Employed by Various Commercial Chip Placers

Detection method	Typical model	Manufacturer
A Vacuum sensor system	Pulsar 100 series 120C, 140C, 135C	CKD
	Panasert MIC, MID, MA, MF	PANASONIC
	ECM series	MAMIYA ELECTRONICS
	OCM-8000 series	OKANO ELECTRIC
	AM100 series	MATSUSHITA ELECTRIC WORKS
B Vacuum sensor + photocell system	CM-60F, -62F, -60P, -62P, -92P	KYUSHU MATSUSHITA ELECTRIC
C Photocell (line sensor) system	TCM-40, -41, -60	SANYO
	Panasert MK I, MK II, MKH, MQ, MQ1, MQ2	PANASONIC
	Bulser 200 series	CKD
D Image processing (CCD camera) system	Panasert MSH, MSH-II, MV II, MV II-F, MPA-V	PANASONIC
	TCM-1000, -1200, -3000	SANYO
	CP-6, CP IV-3	FUJI MACHINERY
	CM86C, 85C, 82C	KYUSHU MATSUSHITA ELECTRIC

Taping Versions

Taping versions of products are available as listed in the table on the right.

Series	Tape width	Pitch
RVG4M	12mm	8mm
POZ3AN, RVG3	8mm	4mm
POZ3KN	12mm	4mm
POG5AN	16mm	12mm
POG5HN	12mm	8mm

5 Chip Mounting Process

4. Sensor Level Adjustment

Adjusting Procedure

A sensor level adjustment should be made as follows:

- ① Check to see if the detection circuit has one sensor line or more. (See the figure on the right.)
- ② According to the figure on the right, attach a vacuum gauge (for example, Bourdon tube) in a specified manner which depends on the circuit layout.
- ③ Read the vacuum pressure (P1) while nothing is being picked up (the nozzle is open).
Example: P1=-30 mmHg
- ④ Have the product picked up and read the vacuum pressure (P2) at this moment.
Example: P2=-90 mmHg
If the chip placer is provided with positioning claws, the claws should be held in their closed positions during pick-up. If the vacuum pressure varies depending on whether the claws are open or closed, the timing of their closing may be incorrect. Please recheck it.
- ⑤ Using a control (variable resistor), adjust the vacuum pressure (Px) at which the vacuum sensor pilot lamp switches on or off, so that the condition of $P2 < Px < P1$ is met.
Example: Px=-70 mmHg

Now the whole sensor level adjustment procedure is completed.

When the detection circuit has a single sensor line, note that standing-up of the chip cannot be detected in case of small components (2.0 (L) × 1.25 (W) mm, 3.2 (L) × 1.6 (W) mm).

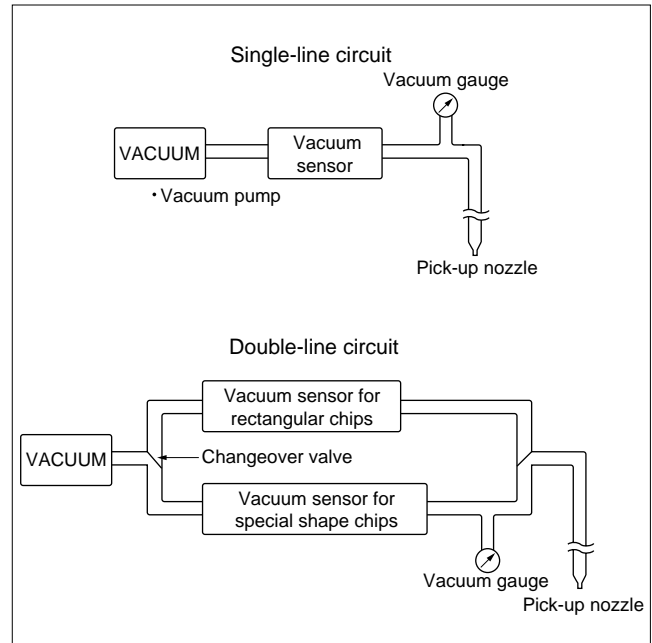

●Chip Placer Positioning Claws

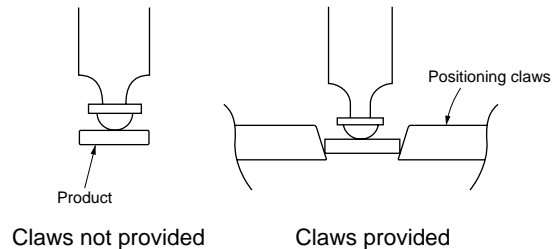

5. Reflow Soldering

Soldering Conditions

If the soldering temperature is too high or the soldering time is too long, leaching of terminations, a drop in torque or a rise in contact resistance might occur. To prevent this, set the optimum soldering conditions, referring to the graph on the right.

If the soldering temperature is too low or the soldering time is too short, the solder would not melt thoroughly and its adhesive strength would be weak.

●Standard Soldering Conditions

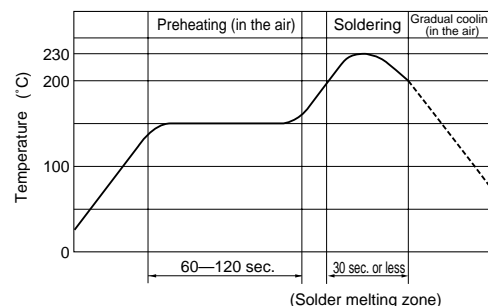

Chip Mounting Process **5**

6. Adhesive Application and Curing

The Amount of Adhesive to Be Applied

Application of an excessive amount of adhesive might unfavorably affect the solderability. On the other hand, if the amount of adhesive applied is insufficient, the product might come off during soldering.

Viscosity of Adhesive

If the viscosity of adhesive is too low, a slip in the product placed on the PCB would easily occur. Use adhesive whose viscosity is 500 ps or more at 25°C.

Points of Application

Adhesive should be applied to two points more than 0.3mm away from the land as shown on the right in the figure, in a manner that it can not protrude through the center hole of the product and stick to the wiper.

Control of Adhesive Curing

If the adhesive applied does not cure well, the adhesive strength would be weak, which might cause peeling-off of the product during soldering. To prevent this, the curing temperature and time should be controlled properly depending on the type of adhesive.

Standard Amounts of Adhesive Applied

Typical adhesives	Standard amounts of application
MR-8153RA	0.6–0.9mg
NF-3000	0.8–1.1mg

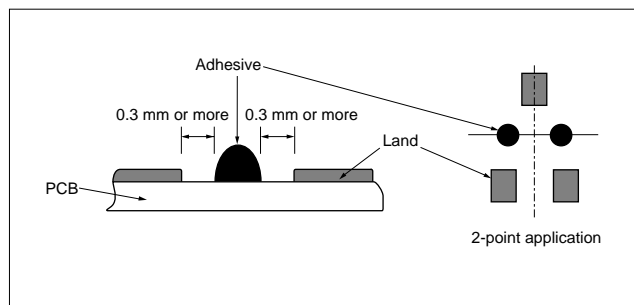

Types and Characteristics of Adhesive

(1) Types of Adhesive

Commercial adhesives for mounting chips temporarily are broadly divided into three types.

- ① Acrylic ultraviolet ray curing type
- ② Polyester ultraviolet ray curing type
- ③ Epoxy thermosetting type

Commonly used commercial adhesives are listed on the next page in the table.

(2) Required Characteristics of Adhesive

- ① When a dispenser is used, a stable discharge of adhesive should be ensured free from trails of thready adhesive.
- ② The adhesive should not loosen easily after it is applied to the PCB.
- ③ The adhesive should be viscous enough to prevent the product from getting out of place due to vibration or movement of the PCB caused by the chip placer.

- ④ High heat resistance and high adhesive strength at high temperatures.
- ⑤ High insulation resistance and excellent moisture resistance.

(3) Adhesive Application Methods

The following three adhesive application methods are available. Select the most suitable method, taking the product mounting method, mounting speed, production volume and other related factors into consideration.

Application method	Features
Dispenser	A sequential application method which allows control of the amount of adhesive according to the type and shape of components.
Screen Printing	A system in which adhesive is applied at a stroke through a screen. This method can save time required for application, though it requires set-up change when PCBs are changed. In this method, no coating is allowed after components are mounted.
Transfer Pin	The application of adhesive is completed at once with transfer pins. The amount of adhesive cannot be controlled in this method.

5 Chip Mounting Process

Commercial Chip Mounting Adhesives

Name	Ingredients	Viscosity	Curing temp. and time	Pot life	Application method	
					Dispenser	Screen printing
MR-8153RA	Acrylic resin*	5500ps	UV.....10" 150°C.....10"min.	2 mos.(30°C)	●	—
NF-1000-6R	Polyester resin*	1800ps	UV.....10–15" 140–150°C.....10"min.	3 mos.(20°C)	●	—
NF-3000		2200ps(H) 1800ps(M) 1300ps(L)	UV.....10–15" 140–150°C.....30"min.			
JU-8V	Epoxy acrylate resin*	400ps	UV.....10"min. 140°C.....10"min.	1 mos.(20°C)	—	●
JU-8VD			●		—	
JT-5S	Epoxy resin*	200ps	140°C.....2.5' min.	3 mos.(20°C)	●	●
ULTRADYNE #5111	Epoxy resin*	500ps	130°C.....15'	1.5 mos.(20°C)	●	●
ULTRADYNE #5111-W5		1300ps				

*Single liquid type

7. Flux Coating

Flux may be coated only on the RVG3A08 and RVG4M series, for which flow soldering is used.

Coating Thickness

If the coating of flux is too thick, a lot of gas would be generated from the flux, which might unfavorably affect the solderability. Make sure that a uniform, thin coating of flux is formed. Foam type flux coating is commonly used for flow soldering.

Ingredients

If the flux contains a high percentage of chlorine (and cleaning has not been done sufficiently), the functionality of the product could be unfavorably affected. It is advisable to use a rosin-based flux which does not contain more than 0.2wt% of chlorine.

Types and Characteristics of Flux

(1) Functions of Flux

Flux is used to increase solderability. Its functions are as follows:

- ① Removing oxides in the base metal
- ② Preventing oxidization during heating
- ③ Decreasing the surface tension of solder

(2) Types of Flux

There are two types of flux:

- ① Rosin flux
- ② Mildly activated flux

(3) Cautions in Use

- ① Rosin flux may be used usually without cleaning.
- ② In case of mildly activated flux, if the chlorine content is too high, corrosion in external terminations or electrodes might occur due to the chlorine. For this reason, flux with a chlorine content of less than 0.2wt% should be used.

(4) Typical Commercial Flux

Flux name	Chlorine content
CF-210V	0.08wt%
CF-220V	0.09wt%
GX-15T	0.09wt%
AGF-150X	0.10wt%
Gammalux D-350	0.08wt%

Chip Mounting Process **5**

8. Flow Soldering

Flow soldering can be used only for the RVG3A08 and RVG4M series, but not for the POZ3, RVG3S08 and POG5 series.

Soldering Conditions

If the soldering time is too long or the soldering temperature is too high, consistent product properties could not be maintained. Standard soldering conditions should be observed.

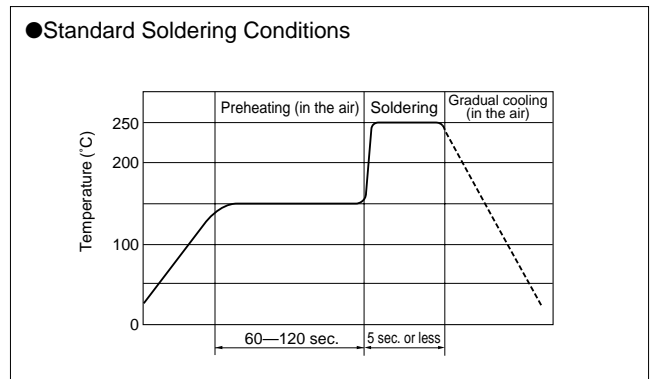

Cautions in Soldering

Attention should be paid to the soldering conditions to ensure that the terminations of the product are soldered properly.

For the RVG3A08 series, the flux left on the surface of the resistive element or the wiper should be removed completely after flow soldering.

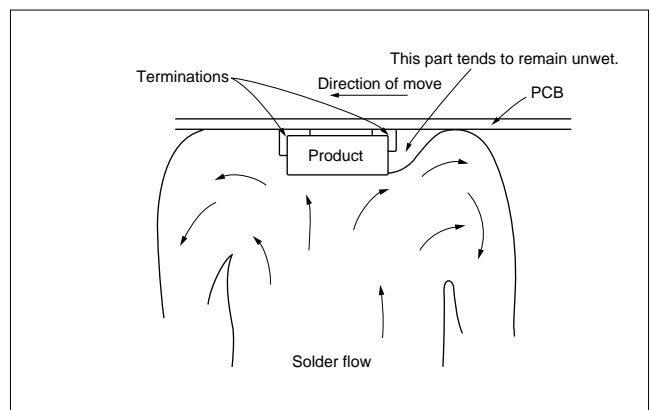

9. Soldering and Resoldering with a Soldering Iron

When carrying out hand soldering with a soldering iron, be careful that the tip of the iron is not excessively hot. If the temperature of the tip is too high, the properties of the product might deteriorate. For the POZ3 and POG5 series, which use a resin substrate or case, special attention should be paid to the temperature of the soldering iron tip.

Care should be taken not to touch any part other than terminals with the soldering iron.

Soldering Conditions

When newly soldering or resoldering the product, observe the following conditions :

- Soldering iron tip temperature : 260°C or less
- Soldering iron tip diameter : 2 mm or less
(1 mm for the tip end)
- Soldering iron wattage : 30 W or less
- Soldering time : 3 sec. or less

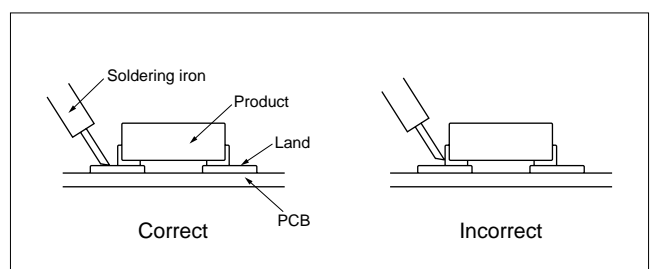

5 Chip Mounting Process

10. Cleaning

Use ethyl alcohol or isopropyl alcohol as a cleaning solvent. For the use of other types of cleaning solvents, consult us beforehand.

Cautions in Cleaning

The cautions to be taken in cleaning somewhat depends on the series.

For the RVG4M and POG5 series, which have a hermetically sealed structure, special considerations as described below are needed.

POG5 Series

Observe the following cleaning conditions:

- ① Dipping, steam or ultrasonic cleaning time should not be more than 3 min.
- ② For ultrasonic cleaning, observe the following conditions:
 Output: 600W (67 liters) or less
 Frequency: 28 kHz
 Temperature: room temperature (5—30°C)

RVG4M Series

To maintain the hermetically sealed structure, observe the recommended cleaning time for each method as shown in the table on the right.

■ Recommended Cleaning Time Range for the RVG4M Series

Conditions	Room temperature dipping	Hot dipping	Ultrasonic (below 20W/ℓ)	Steam cleaning
Method 1	5 min. or less	—	—	—
Method 2	—	2 min. or less	—	—
Method 3	—	—	1 min. or less	—
Method 4	—	1 min. or less	1 min. or less (30 sec. or less recommended)	—
Method 5	—	1 min. or less	30 sec. or less	30 sec. or less

POZ3 and RVG3 Series

In these series, the wiper and resistive element are exposed so flux residue should be removed completely. Any flux residue might damage the functionality of the product. For flow soldering of the RVG3A08 series, cleaning for flux residue removal is indispensable. The cleaning conditions vary depending on the type and volume of flux applied. Determine the optimum cleaning conditions for each application, referring to the above table for the RVG4M series. The prescribed conditions for ultrasonic cleaning (output 20W/ℓ or less, cleaning time 1 min. or less) should be strictly observed to avoid a breakdown of the product due to metal fatigue.

6 Adjustments and Lock Painting

1. Adjustments

The following points should be taken into account when the resistance is adjusted with an adjuster inserted into the product.

Adjuster and Load

If an excessive load is applied to the resistance adjuster, the driver plate or wiper might deform or the PCB might crack. Therefore, the load applied should not be more than 4.9 N (500 gf), preferably below 100 gf.

Inspection of the Adjuster

If the adjuster does not fit the adjuster slot in the product or if its tip is worn, adjustments will not be easy. An adjuster with a worn tip would not engage in the slot properly. Check the tip periodically.

Range of Rotation of the Adjuster

The POZ3, RVG3A08 and RVG4M series have no stopper mechanism to prevent an excessive driver plate rotation. If the driver plate is turned beyond the electrically effective range, the circuit between terminals (1) and (2) and that between terminals (2) and (3) will open. The whole circuitry should be carefully designed so that it can not be irrevocably damaged even if this occurs. Please note that the product's functionality may be damaged if the plate is turned beyond the electrically effective range repeatedly.

Types of Adjuster

For automatic adjustments of the POZ3, RVG3S08 and RVG3A08 series, we recommend a bit for adjusters. (See the next paragraph, "2. Automatic Adjustments".)

■ Recommended Adjusters for Manual Adjustments

Series	Recommended adjusters			
	Manufacturer	Trade name	MURATA's trade name	Head shape
POZ3	VESSEL MFG.	NO.9000+1.7×30	KMPOT12V	Cross
	TORAY INDUSTRIES, INC.	TORAY TORAYCERAM ADJUSTER SA-2225	KMPOT13T	Flat blade (semicircular end)
RVG3S08/3A08	VESSEL MFG.	NO.9000+1.7×30	KMPOT12V	Cross
	TORAY INDUSTRIES, INC.	TORAY TORAYCERAM ADJUSTER SA-2225	KMPOT13T	Flat blade (semicircular end)
RVG4M	VESSEL MFG.	NO.9000—2.6×30	KMPOT15V	Flat blade
POG5	VESSEL MFG.	NO.9000—1.3×30	KMPOT16V	Flat blade
	FUTABA TOOL MFG.	DA54		Flat blade

6 Adjustments and Lock Painting

2. Automatic Adjustments

In the POZ3, RVG3S08 and RVG3A08 series, an adjusting bit can be used for easy automatic adjustments.

Guiding Mechanism for Position Error Correction

After being soldered, the product may be slightly out of place because of land pattern errors or slippage during soldering. Such positional errors can be corrected by installing an image sensor, but this method involves problems about the installation cost and correction speed.

As an alternative solution, provision of a "guiding mechanism" on the product or adjusting bit is recommended. This ensures low installation cost and quick correction.

A guiding mechanism for automatic positional error correction is formed by an adjusting bit combined with the POZ3, RVG3S08 or RVG3A08 series. As shown in the figure on the right, the product position can be corrected by up to ± 0.7 mm in both the X and Y directions.

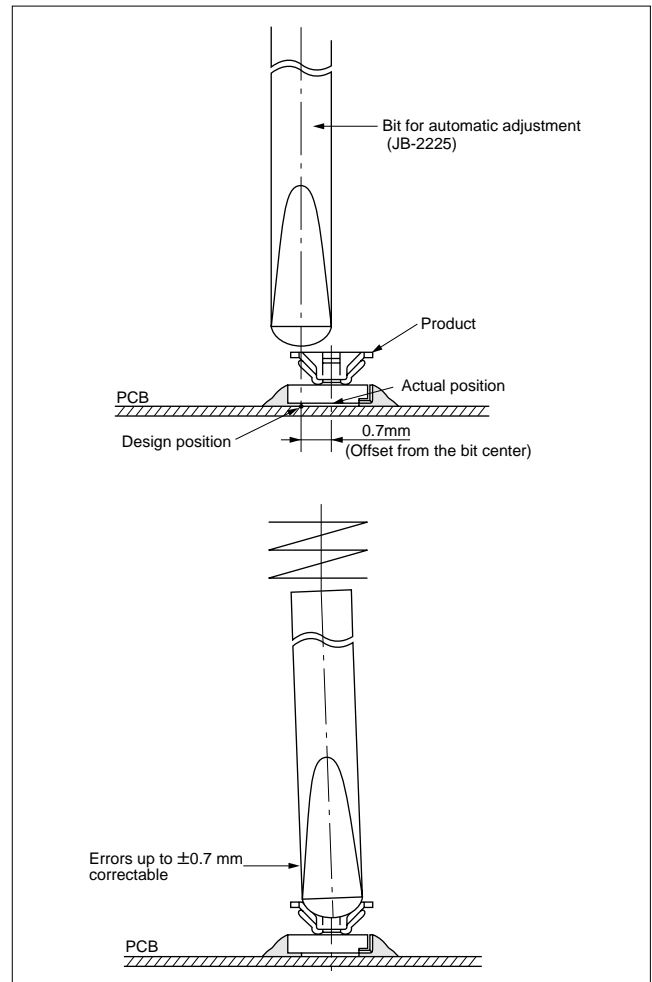

Recommended Bit for Automatic Adjustments

We recommend TORAY TORAYCERAM ADJUSTER JB-2225 (our trade name:KMPOT31T) as a bit for the above-mentioned adjustment purpose. Made of zirconia ceramics, it is highly resistant to abrasion. Also, since it is electromagnetically non-inductive and electrically non-conductive, it can be used in the high frequency range.

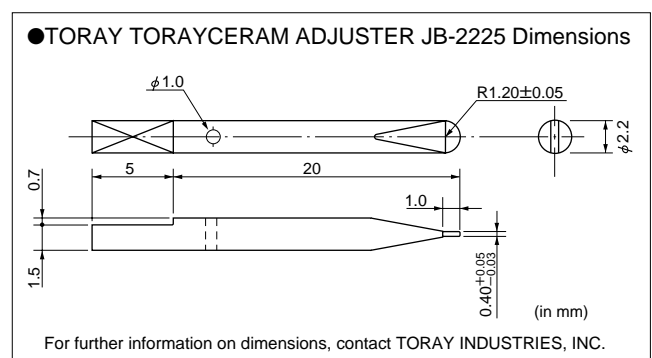

Recommended Adjuster Bit for Automatic Adjustment

Series	Recommended adjuster bit			
	Manufacturer	Trade name	MURATA's trade name	Head shape
POZ3 RVG3S08 RVG3A08	TORAY	TORAY TORAYCERAM ADJUSTER JB-2225	KMPOT31T	Flat blade (semicircular end)

Adjustments and Lock Painting **6**

3. Lock Painting

Lock paint can be coated on the RVG4M and POG5 series (sealed type).

If a product of a series other than the RVG4M and POG5 series needs to be painted, be sure to consult us beforehand.

Paint Ingredients

Lock paint should not contain ingredients which harm the material of the product such as chlorine and sulfur. Before application of lock paint, consult us.

7

Examples of Improper Application and Prevention of the Troubles

Chip trimmer potentiometers are relatively complicated structural parts with contacts. After being soldered to the PCB, they need adjustments. Therefore, improper handling of the product can cause it to malfunction. Various types of trouble caused by improper handling as well as means to prevent such trouble are explained next.

Ex.1. Poor Contact Caused by Flux Adhesion

Phenomenon

The contact between the resistive element and wiper is unstable due to adhesion of flux. As a result, adjustment of resistance is not easy.

(This type of trouble will not occur in the RVG4M and POG5 series since they are of the sealed type.)

Prevention

Take the measures described below to prevent flux from adhering to the resistive element or wiper:

- ① When the product is to be mounted on the front side of the PCB by reflow soldering while flow soldering is to be used on the back side, the arrangement of components and through holes should be carefully determined or the dimensions of land patterns should be decreased in the PCB design process. (See "3.Design of Printed Circuit Boards".)
- ② Decrease the thickness of solder paste coating and reduce the flux content.
- ③ When a soldering iron is used, use thread solder which has a V slot or a perforation to prevent splashing of flux. The amount of solder applied should be minimized.

If splashing of flux cannot be prevented, cleaning or switching to the sealed type should be considered.

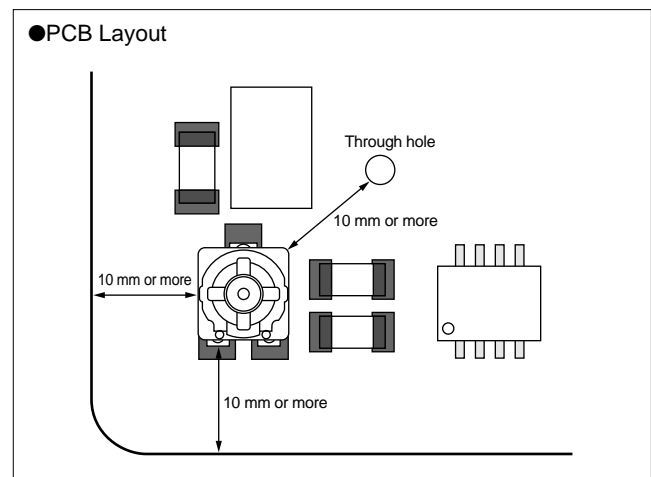

Examples of Improper Application and Prevention of the Troubles **7**

Ex.2. Cracking of the Substrate

Phenomenon

There is a crack in the substrate of the product, its resistance cannot be adjusted and the circuit becomes open.

Prevention

To prevent an excessive load to the substrate in the process of cutting units off the PCB stock or during resistance adjustment, take the cautions described below. When each unit is to be taken from PCB stock, measures ① and ② as described below are effective in eliminating or reducing warping of the PCB.

- ① To facilitate the cutting process to reduce warping, an adequate perforation or sufficiently large slits or V slots should be provided.
- ② It is advisable to use the cutting method instead of the bending method to break the PCB stock into units.
- ③ To avoid the application of an excessive load with an adjuster, the specified adjustment procedure should be observed. (See "6.1 Adjustments".)

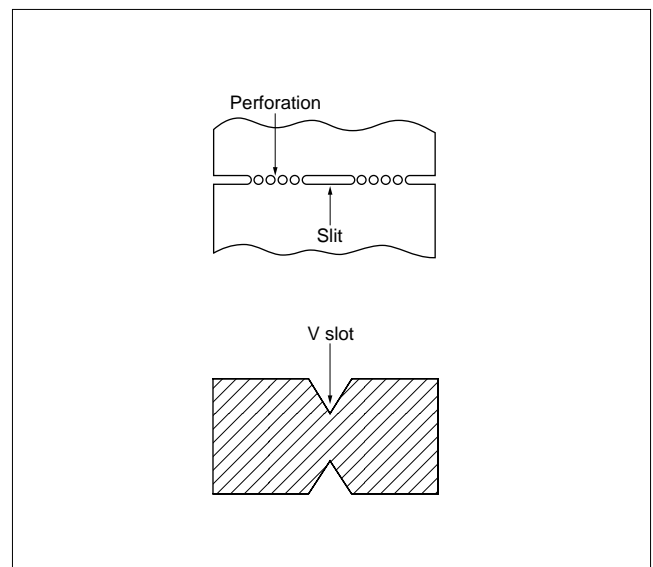

Ex.3. Poor Contact Caused by a Deformed Driver Plate

Phenomenon

The driver plate is deformed, so adjustment is not easy. The wiper is also deformed so the contact between the wiper and resistive element is defective.

Prevention

To prevent an excessive load to the driver plate during transportation of the product or resistance adjustment, take the cautions described below.

- ① Make sure that there is no possibility of a load being directly applied to the product during the PCB transportation. For example, transportation methods which may give a strong impact or stress to the driver plate such as stacking of PCBs or the use of a chute should be avoided.
- ② To avoid the application of an excessive load with an adjuster, the specified adjustment procedure should be observed. (See "6.1 Adjustments".)

**Note:**

1. Export Control

〈For customers outside Japan〉

Murata products should not be used or sold for use in the development, production, stockpiling or utilization of any conventional weapons or mass-destructive weapons (nuclear weapons, chemical or biological weapons, or missiles), or any other weapons.

〈For customers in Japan〉

For products which are controlled items subject to "the Foreign Exchange and Foreign Trade Control Law" of Japan, the export license specified by the law is required for export.

2. Please contact our sales representatives or engineers before using our products listed in this catalog for the applications requiring especially high reliability what defects might directly cause damage to other party's life, body or property (listed below) or for other applications not specified in this catalog.

- ① Aircraft equipment
- ② Aerospace equipment
- ③ Undersea equipment
- ④ Medical equipment
- ⑤ Transportation equipment (automobiles, trains, ships, etc.)
- ⑥ Traffic signal equipment
- ⑦ Disaster prevention / crime prevention equipment
- ⑧ Data-processing equipment
- ⑨ Applications of similar complexity or with reliability requirements comparable to the applications listed in the above

3. Product specifications in this catalog are as of September 1997, and are subject to change or stop the supply without notice. Please confirm the specifications before ordering any product. If there are any questions, please contact our sales representatives or engineers.

4. The categories and specifications listed in this catalog are for information only. Please confirm detailed specifications by checking the product specification document or requesting for the approval sheet for product specification, before ordering.

5. Please note that unless otherwise specified, we shall assume no responsibility whatsoever for any conflict or dispute that may occur in connection with the effect of our and/or third party's intellectual property rights and other related rights in consideration of your using our products and/or information described or contained in our catalogs. In this connection, no representation shall be made to the effect that any third parties are authorized to use the rights mentioned above under licenses without our consent.

6. None of ozone depleting substances (ODS) under the Montreal Protocol is used in manufacturing process of us.

 **Murata Manufacturing Co., Ltd.**<http://www.murata.co.jp/>**Head office**

2-26-10, Tenjin Nagaokakyo-shi, Kyoto 617-8555, Japan Phone:81-75-951-9111

Marketing Group1874 Sumiyoshi-cho Kizuki, Nakahara-ku Kawasaki, 211-0021, Japan
Phone:81-44-422-5153 Fax:81-44-433-0798