

REV. NO./ 版次	REVISION NOTE/ 修订注释	DATE/日期	SIGNATURE/签名

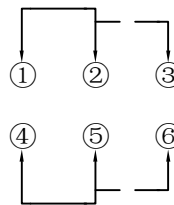

SCHEMATIC

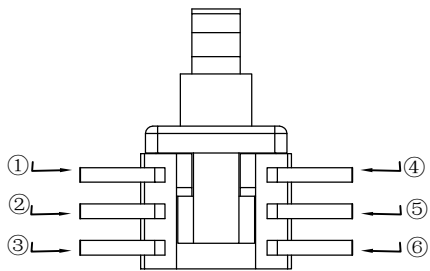
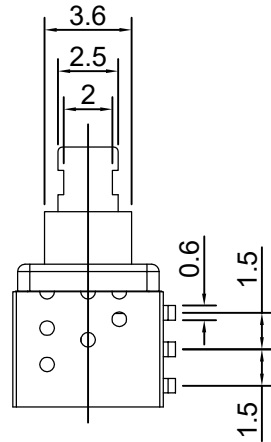
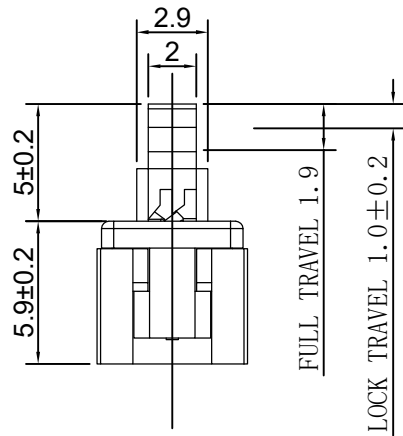
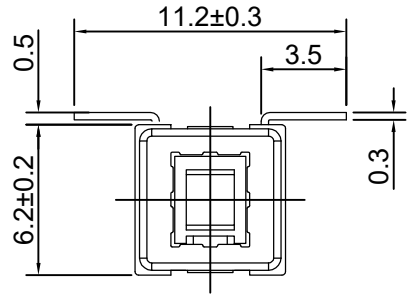
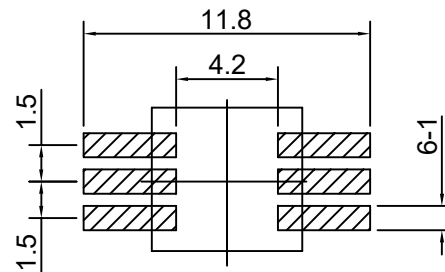

P. C. B LAYOUT

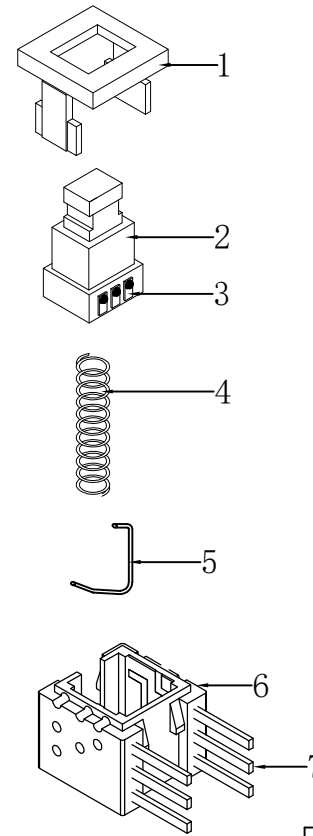

### ELECTRICAL CHARACTERISTICS

1. RATING: DC 30V 0.1A
2. CONTACT RESISTANCE: 100mΩ MAX
3. INSULATION RESISTANCE: 100MΩ MIN
4. DIELECTRIC STRENGTH: AC 250V (50~60Hz)/60S

### MECHANICAL CHARACTERISTICS

1. PRACTICAL TEMPERATURE RANG: -40℃~+85℃
2. OPERATING FORCE: 180±30gf
3. MECHANICAL LIFE: 30,000 cycles

7	TERMINAL	BRASS	6	Ag PLATED
6	CASE	PPA	1	GRAY
5	LOCK PIN	SUS WIRE $\phi 0.35$	1	NATURAL
4	SPRING	SUS WIRE	1	NATURAL
3	CONTACT	BRONZE	2	Ag PLATED
2	KNOB	PPA	1	WHITE
1	COVER	PPA	1	BLACK
NO.	PART NAME	MATERIAL	QTY.	FINISHING

GENERAL TOLERANCE未指的公差		TITLE		
X. ± 0.5	X. ° ± 5°	名称 PB60L180C-S		
.X ± 0.3	.X ° ± 2°	PART NO. 零件编号		DWG NO. 图纸编号
.XX ± 0.2	.XX ° ± 1°	H-PB60L180C-S		
.XXX ± 0.1	.XXX ° ± 0.5°			
APPROVAL 审批	CHECKED 核准	DRAWN 设计	UNIT 单位 (mm)	SCALE 比例
				1:1
				PROJ.
				REV.