

NOTES:
 1.MATERIAL:
 HOUSING:THERMOPLASTIC HIGH TEMP., WITH 30% GLASS FIBER
 UL94V-0, BLACK COLOR
 COLOR:BLACK
 CONTACT:BRASS C2680R EH,T=0.25mm
 BOARD LOCK:BRASS C2680R H,T=0.30mm
 2.FINISH:
 CONTACT:15u" GOLD/TIN PLATING ON CONTACT AREA
 100u" MIN. TIN-LEAD PLATING ON SOLDER TAILS
 50u" MIN.NICKEL UNDERPLATING OVER ALL
 BOARD LOCK:100u" MIN. TIN-LEAD PLATING ON SOLDER TAILS
 50u" MIN.NICKEL UNDERPLATING OVER ALL

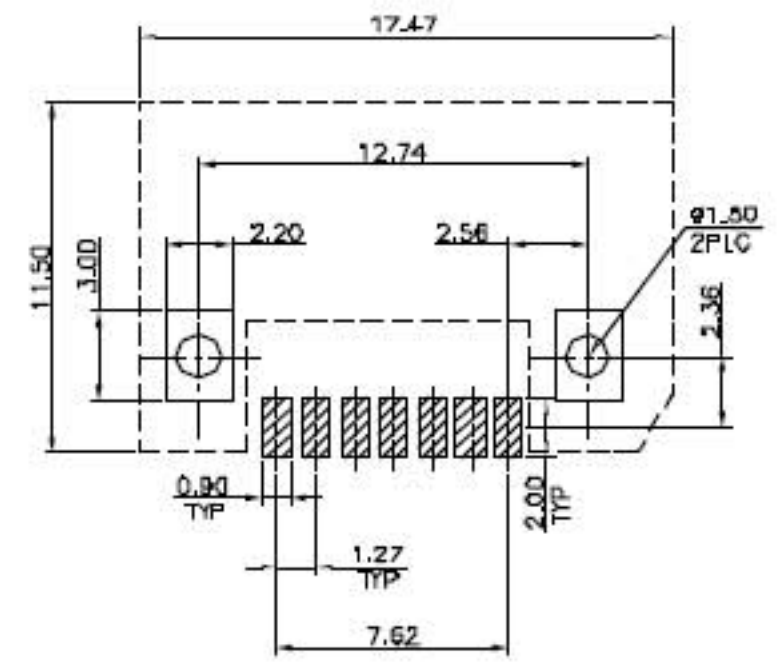

RECOMMEND PCB LAYOUT
 PCB TOLERANCE:±0.05

UNIT : mm

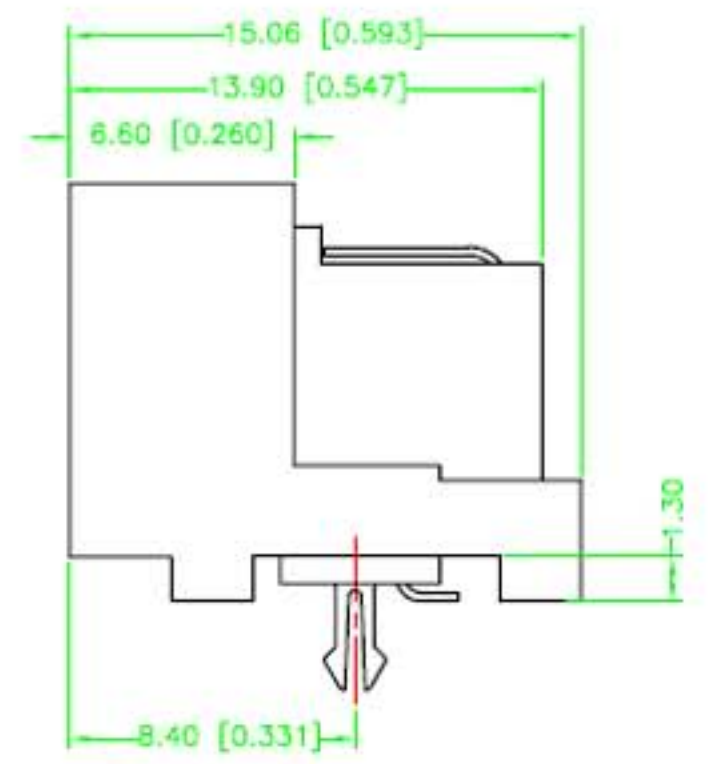
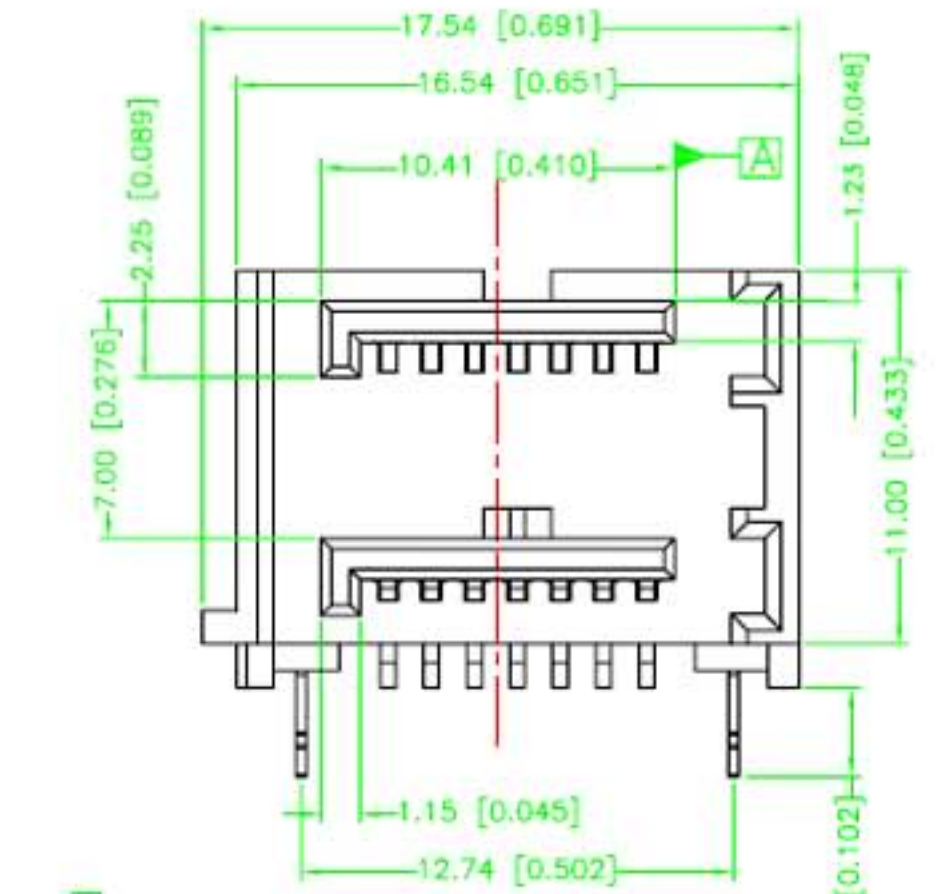

NOTE:

- MATERIAL:
 BASE: LCP+30% GF BLACK
 CONTACT: BRASS C2680-H T=0.25mm
 FORKLOCK BRASS C2680-H T=0.30mm
- TERMINAL PLATING:
 CONTACT AREA: GOLD
 SOLDER AREA : TIN-LEAD(Sn-Pb)ALLOY,75 MICRINCH MINIMUM
 UNDER PLATE : NICKEL (Ni),50 MICRINCH MINIMUM
- FORKLOCK PLATING: THICKNESS=75 MICRINCH MINIMUM. TIN-LEAD (Sn-Pb) ALLOY,
- THE DIMESION MAKED WITH ▼ MUST BE CONTROLLED

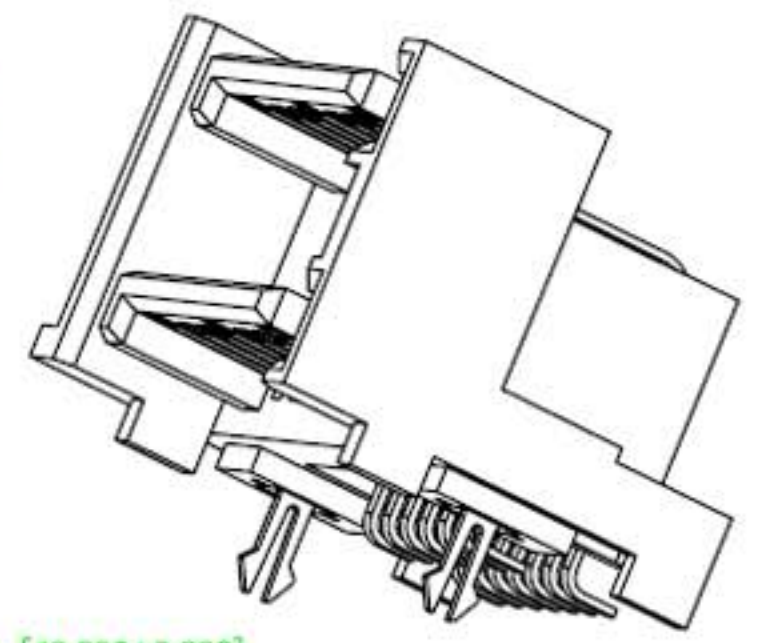
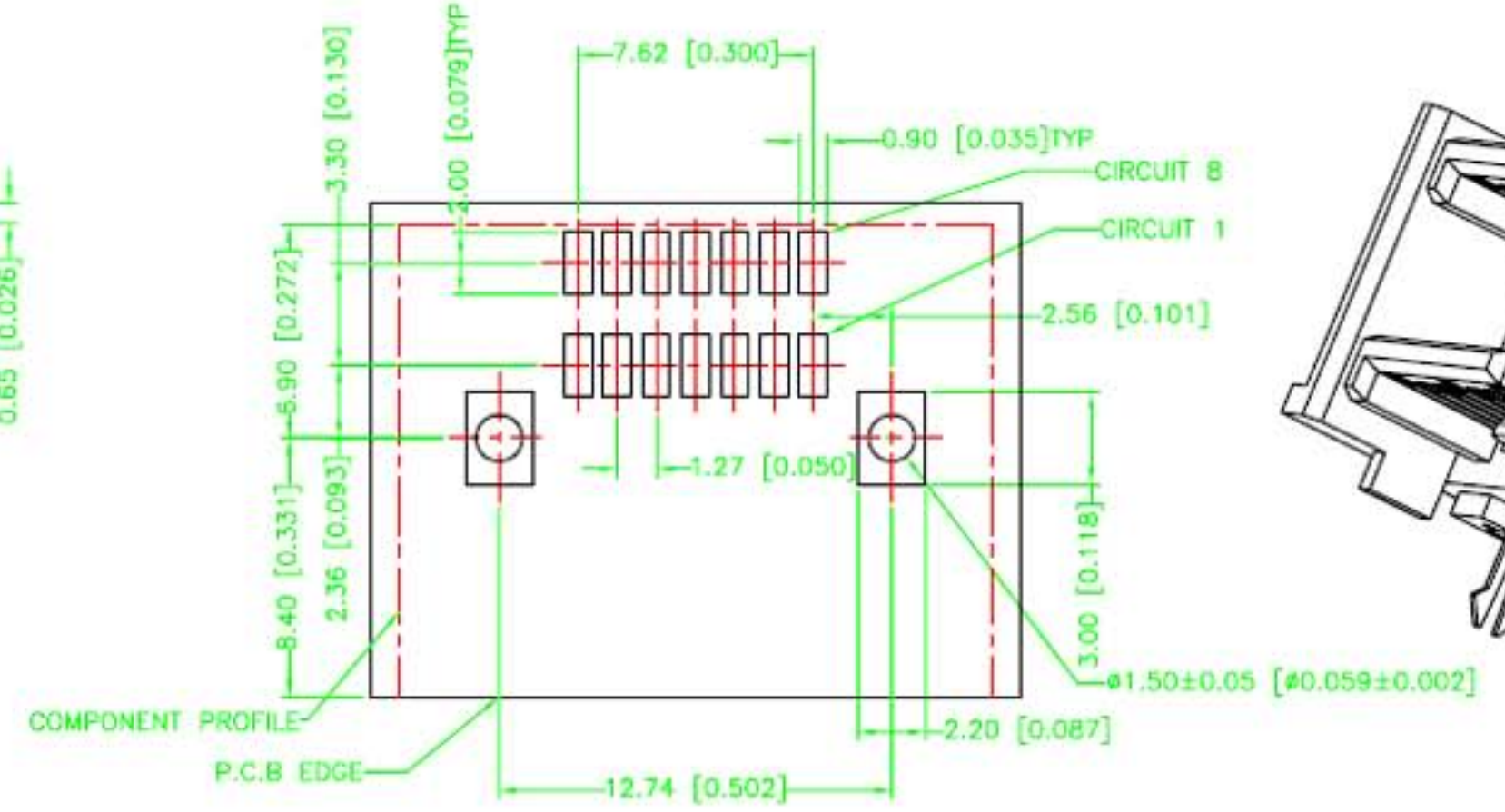
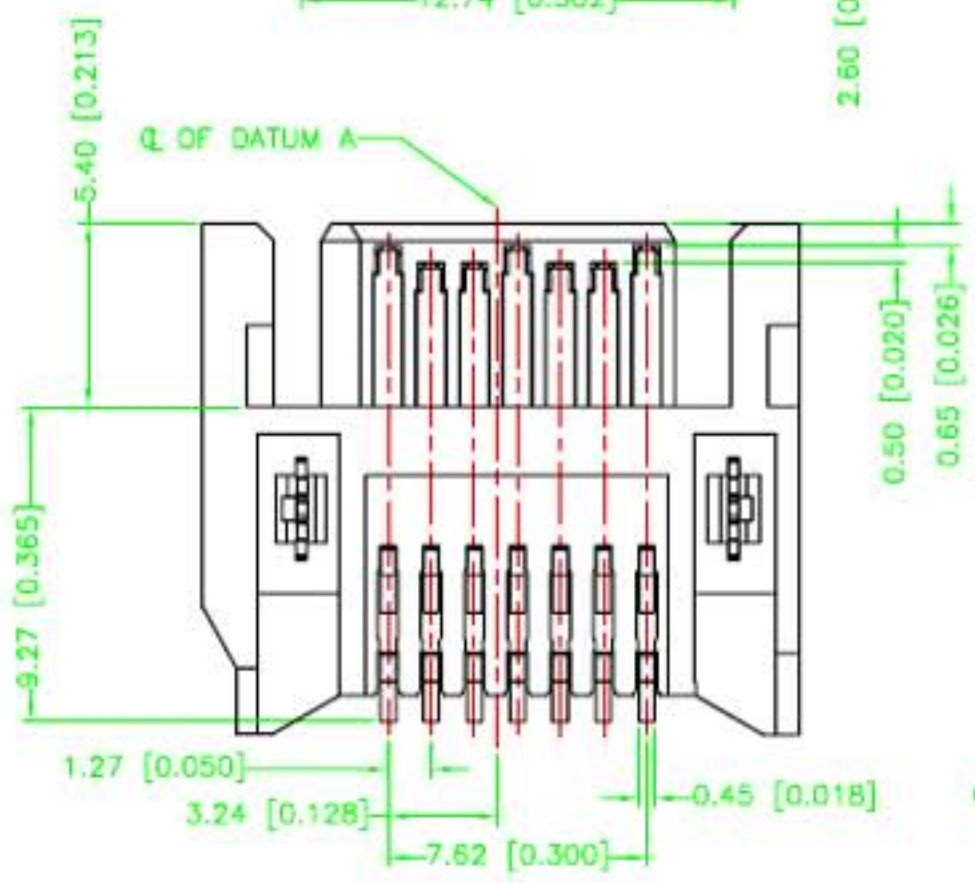

P.C.B LAYOUT
 COMPONENT SIDE

UNIT : mm