

Metal Alloy Low-Resistance Resistor Specifications

October 2010

Specification Number : GCT-SPEC-011-13

Issued Date : 2010/10/01



1. Scope:

- 1.1 This specification is covered following products:
 - 1.1.1 LR1206 series.
 - 1.1.2 LR2010 series.
 - 1.1.3 LR2512 series.
 - 1.1.4 LR2725 series.
 - 1.1.5 LR2728 series.

2. Product Features:

- 2.1 Ideal for all types of current sensing, voltage division and pulse applications including switching and linear power supplies, Instruments, power amplifiers.
- 2.2 Proprietary processing technique produces extremely low Resistance values.
- 2.3 High-temperature performance (up to +170°C).
- 2.4 Metal Strip resistive material stable and ultra low TCR. Low and Stable TCR $\leq \pm 50 \text{ppm}/^\circ\text{C}$.
- 2.5 Pure tin plating provides compatibility with lead (Pb) free and lead containing soldering processes.
- 2.6 Compatible with "Restriction of the use of Hazardous Substances" (RoHS) directive 2002/95/EC (issue 2004).
- 2.7 PFOS, PFOA, PAHs, Halogen free and REACH compliant.
- 2.8 Excellent stability ($|\Delta R/R| \leq \pm 1.0 \%$ for 1,000 h at 70 °C) different environmental conditions.
- 2.9 High volume product suitable for commercial and special applications.
- 2.10 Suitable for high precision current sensing circuit protection application.
- 2.11 Miniature size suitable for compact Print Circuit Boards of high-precision electronic products.

3. Product Applications:

- 3.1 Power Supply.
- 3.2 Battery Pack.
- 3.3 DIY Tools.
- 3.4 Inverter/Converter (AC/DC, DC/DC, DC/AC).
- 3.5 Measurable Instrument.
- 3.6 Consumer Electrics.
- 3.7 Note Book.
- 3.8 PC Power Pack.
- 3.9 LED Driver.
- 3.10 Others (Auto Tronics... etc.).

4. Product Description:

- 4.1 The resistors are constructed in a high grade Materials. Internal metal electrodes are added at each end and connected by a resistive paste that is applied to the top surface of the metal alloy.
- 4.2 The resistive layer is covered with a protective coat, and two external end terminations are added. Wrap-around terminations have an electroplated nickel barrier and pure Tin (lead free) finish, ensuring excellent 'leach' resistance properties and solderability.

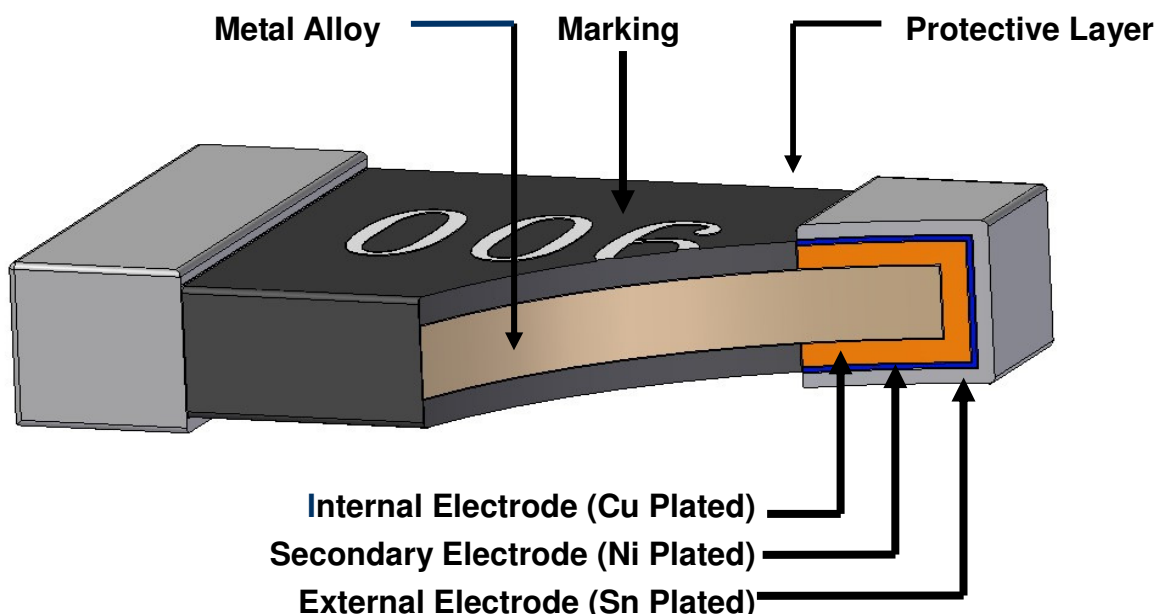

5. Product Specifications:

| Type | # of Terminals | Max. Rating Power | Max. Rating Current | Max. Overload Current | TCR (ppm/°C) | Resistance Range (mΩ)** | | Operating Temperature |
|--------|----------------|-------------------|---------------------|---------------------------------------|---|-------------------------|---------------------------------|-----------------------|
| | | | | | | D (±0.5%) | F (±1%); G (±2%); J (±5%) | |
| LR1206 | 2 | 0.5W | 22.36A | 44.72A | 1.0~4.0m : ±50 4.1~15.0m : ±25 15.1~50.0m : ±15 | 7.0~50.0 | 1.0~50.0 | -55~+170°C |
| | | 1W | 31.62A | 63.25A | 1.0~4.0m : ±50 4.1~15.0m : ±25 15.1~50.0m : ±15 | 7.0~50.0 | 1.0~50.0 | |
| LR2010 | | 1W | 31.62A | 63.25A | 1.0~3.0m : ±50 3.1~6.9m : ±25 7.0~100m : ±15 | 3.0~100 | 1.0~100 | |
| LR2512 | | 1W | 44.72A | 100.00A | 0.5~3.0m : ±50 3.1~6.9m : ±25 | 7.0~100 | 0.5~100 | |
| | | 1.5W | 54.77A | 122.48A | 7.0~100m : ±15 | | | |
| | | 2W | 63.25A | 141.42A | 0.5~3.0m : ±50 3.1~6.9m : ±25 7.0~75.0m : ±15 | 7.0~75.0 | 0.5~75.0 | |
| LR2725 | | 3W | 77.46A | 134.16A | 0.5~2.5m : ±50 2.6~10.0m : ±25 | 7.0~10.0 | 0.5~10.0 | |
| | | 4W | 126.49A | 252.95A | 0.25~0.9m : ±50 1.0~3.0m : ±25 | -- | 0.25~3.0 | |
| LR2728 | | 3W | 27.39A | 47.43A | 4.0~7.0m : ±25 7.1~100m : ±15 | 4.0~100 | 4.0~100 | |
| | 3.5W | 29.58A | 51.23A | 4.0~7.0m : ±25 7.1~100m : ±15 | 4.0~100 | 4.0~100 | | |
| | 4W | 31.62A | 63.25A | 4.0 ~ 7.0m : ±25 7.1 ~ 50.0m : ±15 | 4.0~50.0 | 4.0~50.0 | | |

Remark:

- a. The Max. Power Rating is operated at 70°C.
- b. "***" special tolerance and range of resistance are under requested.

6. Power Derating Curve:

- 6.1 The Operating Temperature Range: -55°C ~+170°C.
- 6.2 For resistors operated in ambient temperatures 70°C, power rating must be derated in accordance with the curve below:

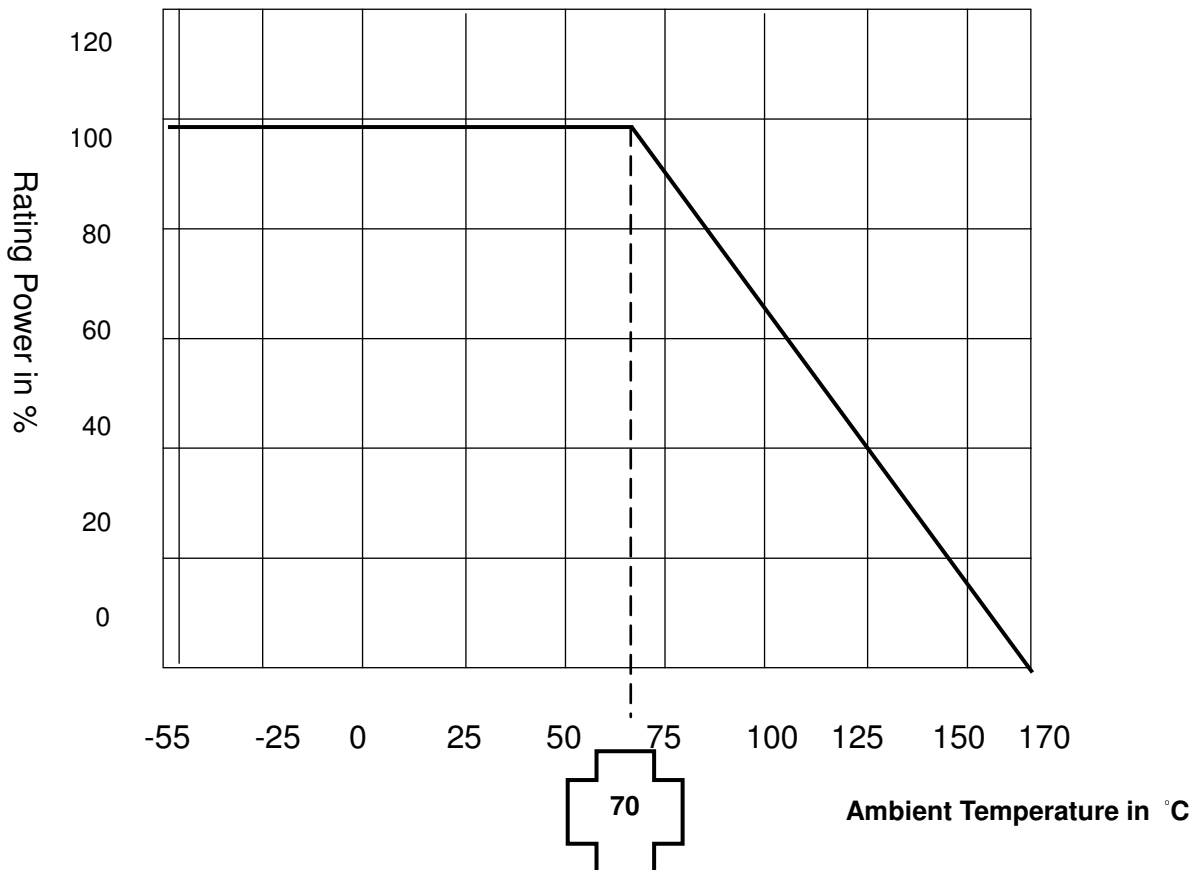

7. Rating Current:

- 7.1 The following equation may be used to determine the DC (Direct Current) or AC (Alternating Current) currents (RMS, root mean square value) of normal rated power. However, if the result value exceeds the highest current of regulated standards (paragraph 5), the highest normal rated power is to be used.

$$I = \sqrt{P/R}$$

Remark:

- I: Rating Current.
- P: Rating Power.
- R: Resistance.



Metal Alloy Low-Resistance Resistor Specifications

Document Number : GCT-SPEC-011-13

Issue Date : 2010/10/01

Page 6 of 14

8. Order Information:

| Model (Size) | Number of Terminals | Power Rating (Watts) | Resistance* | Tolerance** (D=±0.5%; F=±1.0%; G=±2%); J=±5.0%) | Packing*** |
|-----------------|------------------------|----------------------------|--|---|------------|
| LR1206 | 2 | C (0.5W) | R001 EX : R001=1mΩ ; R010=10mΩ | F | 4 |
| LR1206 | 2 | 1 | R001 EX : R001=1mΩ ; R010=10mΩ | F | 4 |
| LR2010 | 2 | 1 | R001 EX : R001=1mΩ ; R100=100mΩ | F | 2 |
| LR2512 | 2 | 1 | R001 EX : R001=1mΩ ; R0005=0.5mΩ | F | 2 |
| LR2512 | 2 | A (1.5W) | R001 EX : R001=1mΩ ; R010=10mΩ | F | 2 |
| LR2512 | 2 | 2 | R001 EX : R001=1mΩ ; R010=10mΩ | F | 2 |
| LR2512 | 2 | 3 | R001 EX : R001=1mΩ ; R010=10mΩ | F | 2 |
| LR2725 | 2 | 4 | R001 EX : R001=1mΩ ; R00025=0.25mΩ | F | 1 |
| LR2728 | 2 | 3 | R004 EX : R004=4mΩ ; R010=10mΩ | F | 1 |
| LR2728 | 2 | B (3.5W) | R004 EX : R004=4mΩ ; R010=10mΩ | F | 1 |
| LR2728 | 2 | 4 | R004 EX : R004=4mΩ ; R010=10mΩ | F | 1 |

Remark:

- “*” normal product order information has 4 digits, if includes one decimal point then the order information should be 5 digits (e.g. 0.5mΩ is R0005), if includes 2 decimal points, then it should be 6 digits (e.g. 0.25mΩ is R00025).
- The detail marking format please refer to paragraph 13
- “***” Special tolerance and range of resistance are under requested.

Giant Chip Technology Co., Ltd

No.1-4, Kaifa Rd., Nanzih District, Kaohsiung City 81170, Taiwan (R.O.C.), Tel: 886-2-8698-2189, 886-7-301-0468

Fax:886-2-8698-2358, 886-7-301-0467, www.gcttek.com.tw

d. "***" The packing quantity: 4 means 4k pieces per reel; 2 means 2k pieces per reel; 1 means 1k pieces per reel

9. Physical Dimensions:

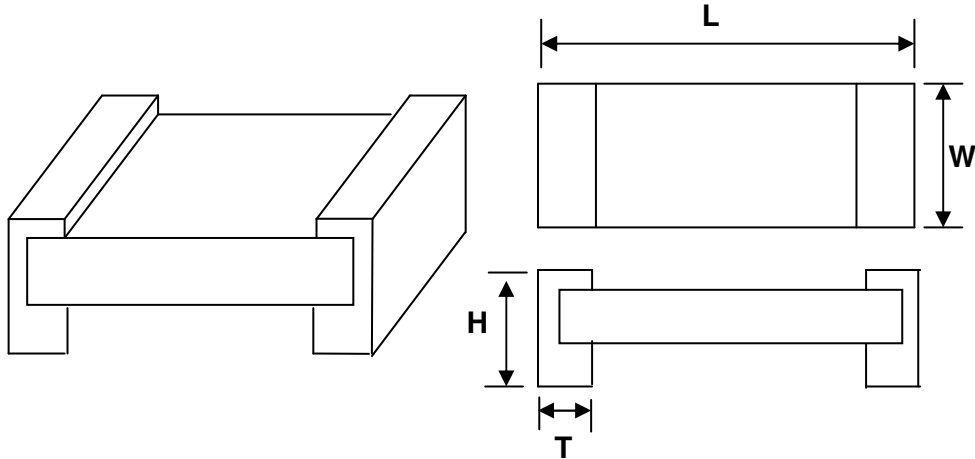

| Type | Maximum Power Rating (Watts) | Resistance Range (mΩ) | Dimensions - in inches (millimeters) | | | |
|--------|------------------------------|---------------------------|--------------------------------------|------------------------------|-------------------------------|------------------------------|
| | | | L | W | H | T |
| LR1206 | 0.5 & 1.0 | 1.0 ~ 50.0 | 0.126±0.010 (3.200±0.254) | 0.063±0.010 (1.600±0.254) | 0.0254±0.010 (0.645±0.254) | 0.020±0.010 (0.508±0.254) |
| LR2010 | 1.0 | 1.0 ~ 3.0 | 0.200±0.010 (5.080±0.254) | 0.100±0.010 (2.540±0.254) | 0.031±0.010 (0.787±0.254) | 0.051±0.010 (1.295±0.254) |
| | | 3.1 ~ 100.0 | | | 0.0254±0.010 (0.645±0.254) | 0.031±0.010 (0.787±0.254) |
| LR2512 | 1.0 & 1.5 | 0.5 ~ 4.0 | 0.246±0.010 (6.248±0.254) | 0.130±0.010 (3.302±0.254) | 0.031±0.010 (0.787±0.254) | 0.074±0.010 (1.880±0.254) |
| | | 4.1 ~ 75.0 | | | 0.0254±0.010 (0.645±0.254) | 0.044±0.010 (1.118±0.254) |
| | | 75.1 ~ 100.0 | | | 0.0254±0.010 (0.645±0.254) | 0.034±0.010 (0.868±0.254) |
| LR2512 | 2.0 | 0.5 ~ 4.0 | 0.246±0.010 (6.248±0.254) | 0.130±0.010 (3.302±0.254) | 0.031±0.010 (0.787±0.254) | 0.074±0.010 (1.880±0.254) |
| | | 4.1 ~ 75.0 | | | 0.0254±0.010 (0.645±0.254) | 0.044±0.010 (1.118±0.254) |
| LR2512 | 3.0 | 0.5 | 0.246±0.010 (6.248±0.254) | 0.130±0.010 (3.302±0.254) | 0.031±0.010 (0.787±0.254) | 0.074±0.010 (1.880±0.254) |
| | | 0.6 ~ 2.9 & 4.1 ~ 10.0 | | | | 0.044±0.010 (1.118±0.254) |
| | | 3.0 ~ 4.0 | | | | 0.066±0.010 (1.676±0.254) |
| LR2725 | 4.0 | 0.25, 0.50 | 0.268±0.010 (6.807±0.254) | 0.254±0.010 (6.452±0.254) | 0.039±0.010 (0.991±0.254) | 0.085±0.010 (2.159±0.254) |
| | | 1.0 | | | 0.043±0.010 (1.092±0.254) | |
| | | 1.5 | | | 0.039±0.010 (0.991±0.254) | |
| | | 2.0 | | | 0.035±0.010 (0.889±0.254) | 0.071±0.010 (1.803±0.254) |
| | | 2.5 | | | 0.065±0.010 (1.651±0.254) | |



| | | | | | | |
|---------------|---------------|-----------|------------------------------|------------------------------|------------------------------|------------------------------|
| | | 3.0 | | | | 0.051±0.010 (1.295±0.254) |
| LR2728 | 3.0、3.5 & 4.0 | 4.0~100.0 | 0.264±0.010 (6.706±0.254) | 0.283±0.010 (7.188±0.254) | 0.039±0.010 (0.991±0.254) | 0.045±0.010 (1.143±0.254) |

10. Product Reliability Performance:

10.1 Electrical Performance:

| Test Item | Conditions of Test | Test Method | Test Limits |
|---|--|-------------------|----------------------------------|
| Temperature Coefficient of Resistance (TCR) | $\text{TCR (ppm/}^\circ\text{C)} = \frac{(R2-R1)}{R1 (T2-T1)} \times 10^6$ <ul style="list-style-type: none"> R1 : resistance of room temperature (T1) R2 : resistance of 150 °C (T2) | JIS C 5201-1 4.8 | Per Spec. (refer to paragraph 5) |
| Short Time Overload | The number of rated power are as follows: <ul style="list-style-type: none"> LR1206-0.5W : 4 times rated power LR1206-1W : 4 times rated power LR2010-1W : 4 times rated power LR2512-1W : 5 times rated power LR2512-1.5W : 5 times rated power LR2512-2W : 5 times rated power LR2512-3W : 3 times rated power LR2725-4W : 4 times rated power LR2728-3W : 3 times rated power LR2728-3.5W : 3 times rated power LR2728-4W : 4 times rated power Rating power duration: 5secs | JIS C 5201-1 4.13 | $(\Delta R/R1) \leq \pm 0.5\%$ |
| Insulation Resistance | 100±15V _{DC} for 1 minute | JIS C 5201-1 4.6 | $\geq 10^9 \Omega$ |
| Dielectric Withstanding Voltage | Applied 500V _{AC} for 1 minute, and Limit surge current 50 mA (max.) | JIS C 5201-1 4.7 | Without break down |

10.2 Mechanical /Constructional Performance:

| Test Item | Conditions of Test | Test Method | Test Limits |
|---------------------------|---|-------------------------|---------------------------|
| Resistance to Solder Heat | Solder temp./immersion time: 260±5°C, 10±1secs and 350±10°C, 3.5±0.5secs | JIS C 5201-1 4.18 | ($\Delta R/R1$) ≤ ±0.5% |
| Solderability test | Specimen prep.: 4 hours ± 15 min. Steam Aging : Solder Bath/Dip and Look Test, 245±5°C, 3±1secs | JIS C 5201-1 4.17 | 95% coverage |
| Vibration | Frequency varied 55Hz in one minute, 3 orientations @ Total duration 12 hours | JIS C 5201-1 4.22 | ($\Delta R/R1$) ≤ ±0.5% |
| Resistance to solvent | Immersion time: 60±5secs @ 20°C~25°C | JIS C 5201-1 4.29, 4.30 | ($\Delta R/R1$) ≤ ±0.5% |
| Mechanical Shock | 100 grams for 6 milliseconds, 5 pulses | JIS C 5201-1 4.21 | ($\Delta R/R1$) ≤ ±0.5% |

10.3 Environmental Performance:

| Test Item | Conditions of Test | Test Method | Test Limits |
|--|---|---------------------|---------------------------|
| Low Temperature Exposure (Storage) | 1,000 hours @ -55°C | JIS C 5201-1 4.23.4 | ($\Delta R/R1$) ≤ ±0.5% |
| High Temperature Exposure (Storage) | 1,000 hours @ + 170°C | JIS C 5201-1 4.23.2 | ($\Delta R/R1$) ≤ ±1.0% |
| Temperature Cycling (Rapid Temperature Change) | Air to air, - 55°C to + 150°C, 1,000 cycles, 15 minutes at each extreme, transition time 2 to 3 minutes | JIS C 5201-1 4.19 | ($\Delta R/R1$) ≤ ±0.5% |
| Moisture Resistance (Climatic Sequence) | Mil-STD-202, Method 106, 0% power, 7a and 7b not required, t = 24 h/cycle, 10 cycles, Unpowered, | JIS C 5201-1 4.23 | ($\Delta R/R1$) ≤ ±0.5% |
| Bias Humidity | + 85 °C, 85% RH, 10% Bias, 1.5 hours On, 0.5 hours Off; extended life test: 1,000 hours, | JIS C 5201-1 4.24 | ($\Delta R/R1$) ≤ ±0.5% |

10.4 Operational Life Endurance:

| Test Item | Conditions of Test | Test Method | Test Limits |
|-----------|---|---------------------|---------------------------|
| Load Life | Test temperature 70 °C rated working voltage, 1.5 hours On , 0.5 hours Off; extended life test: 1,000 hours | JIS C 5201-1 4.25.1 | ($\Delta R/R1$) ≤ ±1.0% |

Remark: R1 means resistance before stress

11. Recommend Solder Pad Dimensions:

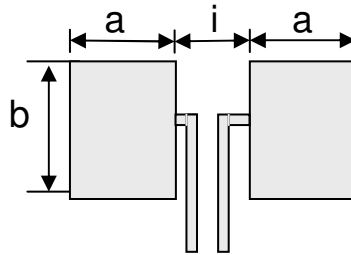

sense

| Type | Maximum Power Rating (Watts) | Resistance Range (mΩ) | Dimensions - in inches (millimeters) | | |
|--------|------------------------------|-----------------------|--------------------------------------|--------------|--------------|
| | | | a | b | i |
| LR1206 | 0.5 & 1.0 | 1.0 ~ 50.0 | 0.063 (1.60) | 0.086 (2.18) | 0.026 (0.66) |
| LR2010 | 1.0 | 1.0 ~ 3.0 | 0.071 (1.80) | 0.115 (2.92) | 0.048 (1.22) |
| | | 3.1 ~ 100.0 | 0.090 (2.29) | 0.115 (2.92) | 0.095 (2.41) |
| LR2512 | 1.0 & 1.5 | 0.5 ~ 4.0 | 0.120 (3.05) | 0.145 (3.68) | 0.050 (1.27) |
| | | 4.1 ~ 100.0 | 0.083 (2.11) | 0.145 (3.68) | 0.125 (3.18) |
| LR2512 | 2.0 | 0.5 ~ 4.0 | 0.120 (3.05) | 0.145 (3.68) | 0.050 (1.27) |
| | | 4.1 ~ 75.0 | 0.083 (2.11) | 0.145 (3.68) | 0.125 (3.18) |
| LR2512 | 3.0 | 0.5 ~ 1.5 | 0.120 (3.05) | 0.145 (3.68) | 0.050 (1.27) |
| | | 1.6 ~ 10.0 | 0.083 (2.11) | 0.145 (3.68) | 0.125 (3.18) |
| LR2725 | 4.0 | 0.25 ~ 3.0 | 0.125 (3.18) | 0.270 (6.86) | 0.052 (1.32) |
| LR2728 | 3.0、3.5 & 4.0 | 4.0 ~ 100.0 | 0.108 (2.75) | 0.308 (7.82) | 0.138 (3.51) |

Remark: The total solder pad trace sizes are recommended as follows:

Unit: mm²

| Power | LR1206 | LR2010 | LR2512 | LR2725 | LR2728 |
|-------|--------|--------|--------|--------|--------|
| 0.5W | 100 | -- | -- | -- | -- |
| 1.0W | 100 | 100 | 100 | -- | -- |
| 1.5W | -- | -- | 200 | -- | -- |
| 2.0W | -- | -- | 300 | -- | -- |
| 3.0W | -- | -- | 400 | -- | 300 |
| 3.5W | -- | -- | -- | -- | 350 |
| 4.0W | -- | -- | -- | 400 | 400 |

12. Recommend Soldering Conditions:

12.1 Surface-mount components are tested for solderability at a temperature of 245 °C for 3 seconds. Typical examples of soldering processes that provide reliable joints without any damage are given in below:

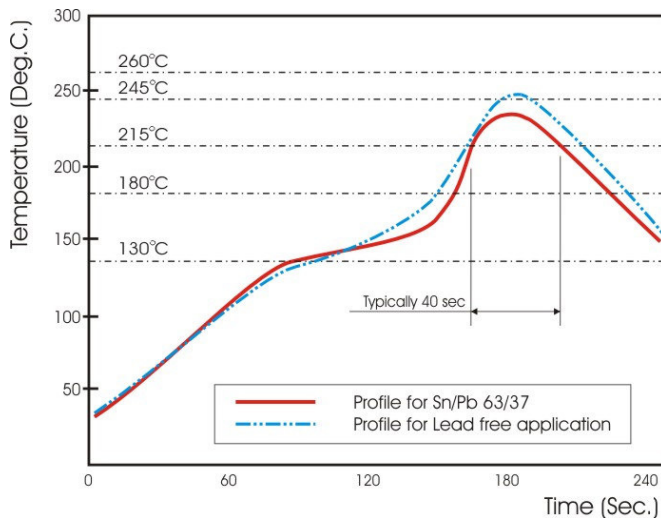

Recommended IR Reflow Soldering Profile

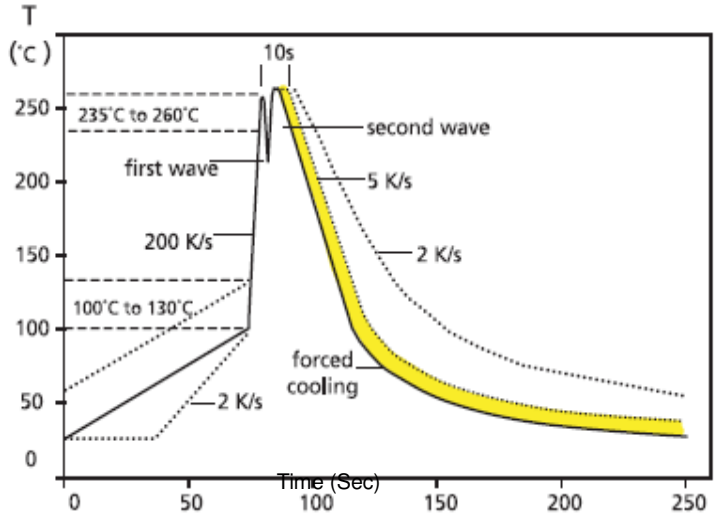

Recommended double-wave Soldering Profile

Typical values (solid line)

Process limits (dotted line)

13. Marking Format:

13.1 Product resistance is indicated by using two marking notation styles:

- a. "R" designates the decimal location in ohms, e.g.
 - For 1mΩ the product marking is R001;
 - For 25mΩ the product marking is R025;
 - For 100mΩ the product marking is R100.
- b. "m" designates the decimal location in milliohms, e.g.
 - For 0.25mΩ the product marking is 0m25;
 - For 0.5mΩ the product marking is 0m50;
 - For 5.5mΩ the product marking is 5m50;
 - For 25.5mΩ the product marking is 25m5.

Remark: all the products marking are 4 digits.

13.2 LR1206 series:



Ex. Resistance 10mΩ (for all LR1206 products)

13.3 LR2010 series:



Ex. Resistance 2mΩ (when resistance below or equal than 3mΩ)

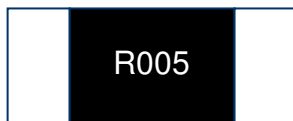

Ex. Resistance 5mΩ (when resistance greater than 3mΩ)

13.4 LR2512 series:



Ex. Resistance 0.5mΩ (when resistance below than 1mΩ)

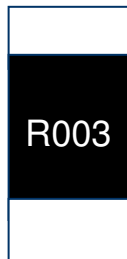

Ex. Resistance 3mΩ (when resistance below or equal than 4mΩ)

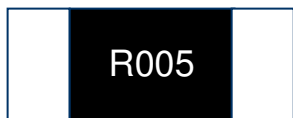

Ex. Resistance 5mΩ (when resistance greater than 4mΩ)

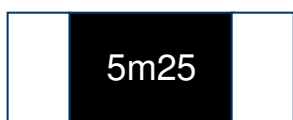

Ex. Resistance 5.25mΩ (when resistance greater than 4mΩ)

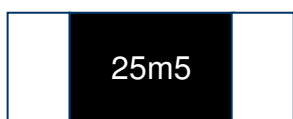

Ex. Resistance 25.5mΩ (when resistance greater than 4mΩ)

13.5 LR2725 series:



Ex. Resistance 0.25mΩ (or 0.25mΩ only)



Ex. Resistance 2.5mΩ (for 1.5mΩ and 2.5mΩ only)

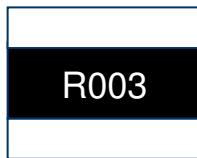

Ex. Resistance 3mΩ (for 1m · 2m and 3mΩ only)

13.6 LR2728 series:

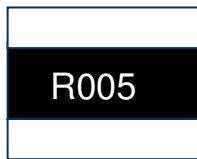

Ex. Resistance 5mΩ (for all LR2728 products)

14. Packaging:

14.1 Embossed Dimensions:

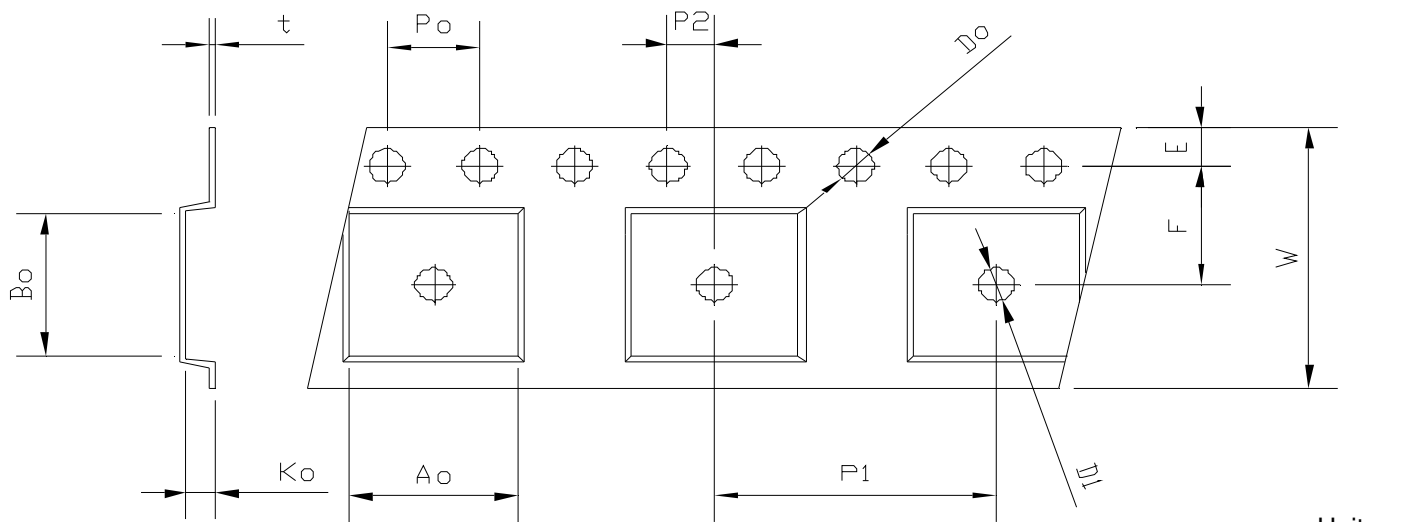

Unit: mm

| Item | W | P1 | E | F | Do | D1 | P0 | Po*10 | P2 | Ao | Bo | Ko | t |
|-----------|-------|-------|-------|-------|-------|-------|-------|-------|-------|-------|-------|-------|-------|
| LR1206 | 8.00 | 4.00 | 1.75 | 3.50 | 1.55 | 1.00 | 4.00 | 40.00 | 2.00 | 1.83 | 3.48 | 0.90 | 0.20 |
| LR2010 | 12.00 | 4.00 | 1.75 | 5.50 | 1.50 | 1.50 | 4.00 | 40.00 | 2.00 | 2.90 | 5.45 | 1.10 | 0.23 |
| LR2512 | 12.00 | 8.00 | 1.75 | 5.50 | 1.55 | 1.50 | 4.00 | 40.00 | 2.00 | 3.90 | 6.74 | 1.08 | 0.24 |
| LR2725 | 12.00 | 8.00 | 1.75 | 5.50 | 1.50 | 1.50 | 4.00 | 40.00 | 2.00 | 6.75 | 7.15 | 1.70 | 0.25 |
| LR2728 | 12.00 | 12.00 | 1.75 | 5.50 | 1.55 | 1.55 | 4.00 | 40.00 | 2.00 | 7.70 | 7.15 | 1.20 | 0.25 |
| Tolerance | ±0.15 | ±0.10 | ±0.10 | ±0.10 | ±0.05 | ±0.10 | ±0.10 | ±0.20 | ±0.10 | ±0.10 | ±0.10 | ±0.10 | ±0.05 |

14.2 Reel Dimensions:

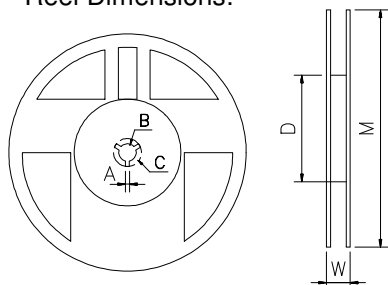

Unit: mm

| Reel Type / Tape | W | M | A | B | C | D |
|---|-------------|-----------|-----------|------------|------------|------------|
| 7" reel for 12 mm embossed | 16.2 ± 0.5 | 178 ± 1.0 | 2.5 ± 0.5 | 13.5 ± 0.5 | 17.7 ± 0.5 | 60.0 ± 0.5 |
| 7" reel for 8 mm embossed (for LR1206 only) | 12.00 ± 0.5 | 178 ± 1.0 | 2.0 ± 0.5 | 13.2 ± 0.5 | 17.7 ± 0.5 | 60.0 ± 0.5 |