

---



---

## ULTRA-LOW VOLTAGE OPERATION CHARGE PUMP IC S-882Z Series FOR STEP-UP DC-DC CONVERTER STARTUP

---



---

The S-882Z Series is a charge pump IC for step-up DC-DC converter startup, which differs from conventional charge pump ICs, in that it uses fully depleted SOI (Silicon on Insulator) technology to enable ultra-low voltage operation.

Being capable of stepping up an extremely low input voltage of 0.3 to 0.35 V, this series enables the efficient use of very low energy levels. The stepped up electric power is stored in a startup capacitor, and it is discharged as the startup power of the step-up DC-DC converter when the startup capacitor reaches the discharge start voltage level.

Moreover, a built-in shutdown function is also provided, so that when the output voltage of the connected step-up DC-DC converter rises above a given value, the operation is stopped, thereby achieving significant power saving and battery life extension.

The S-882Z Series chips come in a small SOT-23-5 package, allowing high-density mounting.

### ■ Features

- Operating input voltage 0.3 to 3.0 V
- Current consumption During operation : 0.5 mA max. (at  $V_{IN} = 0.3$  V)  
During shutdown : 0.6  $\mu$ A max. (at  $V_{IN} = 0.3$  V)
- Discharge start voltage 1.8 to 2.4 V (selectable in 0.2 V steps)
- Shutdown voltage Discharge start voltage + 0.1 V (fixed)
- Oscillation frequency 350 kHz typ. (at  $V_{IN} = 0.3$  V)
- Small package SOT-23-5 package
- External component Startup capacitor ( $C_{CPOUT}$ ), 1 unit\*1
- Lead-free products

\*1. The addition of a Schottky diode or a power smoothing capacitor may be necessary depending on the output smoothing capacitor value of the step-up DC-DC converter and the output voltage value. (Refer to ■ **Example of Connection with Step-up DC-DC Converter.**)

### ■ Applications

- Stepping up from low-voltage power supply such as solar cell and fuel cell
- Stepping up internal power supply voltage of RF tag
- Intermittent power supply to intermittently operating system

### ■ Package

Package Name	Drawing Code		
	Package	Tape	Reel
SOT-23-5	MP005-A	MP005-A	MP005-A

■ Block Diagram

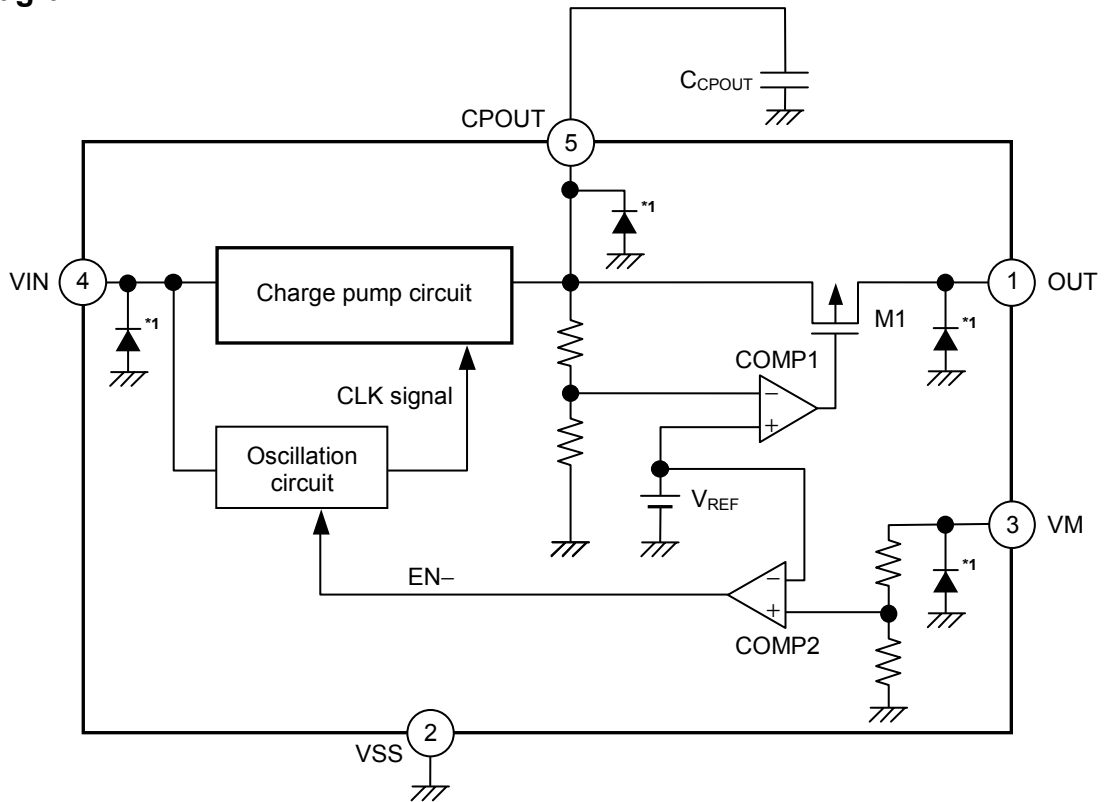

\*1. Parasitic diode

Figure 1

## ■ Product Name Structure

The discharge start voltage for the S-882Z Series can be selected at the user's request. Refer to "1. Product Name" for the definition of the product name and "2. Product Name List" for the full product names.

### 1. Product Name

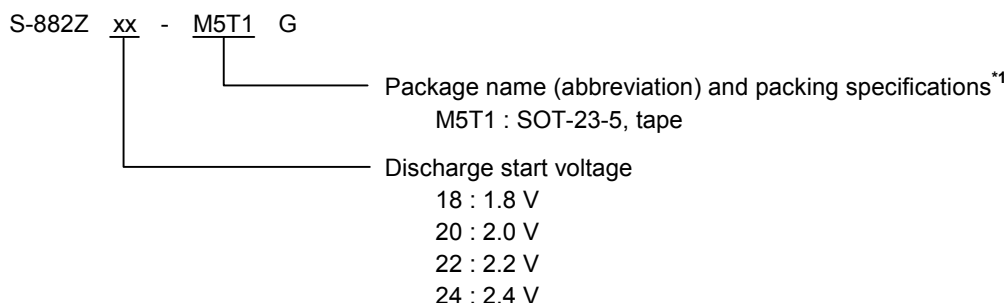

\*1. Refer to the taping specifications at the end of this book.

### 2. Product Name List

**Table 1**

Discharge Start Voltage	Shutdown Voltage	Product Name
1.8 V ± 0.1 V	1.9 V ± 0.1 V	S-882Z18-M5T1G
2.0 V ± 0.1 V	2.1 V ± 0.1 V	S-882Z20-M5T1G
2.2 V ± 0.1 V	2.3 V ± 0.1 V	S-882Z22-M5T1G
2.4 V ± 0.1 V	2.5 V ± 0.1 V	S-882Z24-M5T1G

**Remark** Contact the SII marketing department for products with discharge start voltage other than those specified above.

■ Pin Configurations

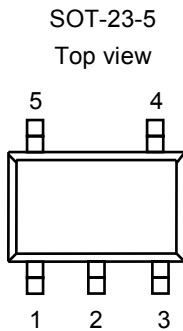

Figure 2

Table 2

Pin No.	Pin Name	Pin Description
1	OUT	Output pin (step-up DC-DC converter connection pin)
2	VSS	GND pin
3	VM	Step-up DC-DC converter output voltage monitor pin
4	VIN	Power supply input pin
5	CPOUT	Startup capacitor connection pin

■ Absolute Maximum Ratings

Table 3

(Ta = 25°C unless otherwise specified)

Parameter	Symbol	Absolute Maximum Rating	Unit
VIN pin voltage	V <sub>IN</sub>	V <sub>SS</sub> – 0.3 to V <sub>SS</sub> + 3.3	V
CPOUT pin voltage	V <sub>CPOUT</sub>	V <sub>SS</sub> – 0.3 to V <sub>SS</sub> + 3.3	V
OUT pin voltage	V <sub>OUT</sub>	V <sub>SS</sub> – 0.3 to V <sub>SS</sub> + 3.3	V
VM pin voltage	V <sub>VM</sub>	V <sub>SS</sub> – 0.3 to V <sub>SS</sub> + 3.3	V
Power dissipation	P <sub>D</sub>	300 (When not mounted on board)	mW
		600 <sup>*1</sup>	mW
Operating ambient temperature	T <sub>opr</sub>	–40 to +85	°C
Storage temperature	T <sub>stg</sub>	–40 to +125	°C

\*1. When mounted on board  
 [Mounted board]

- (1) Board size: 114.3 mm × 76.2 mm × t1.6 mm
- (2) Board name: JEDEC STANDARD51-7

**Caution** The absolute maximum ratings are rated values exceeding which the product could suffer physical damage. These values must therefore not be exceeded under any conditions.

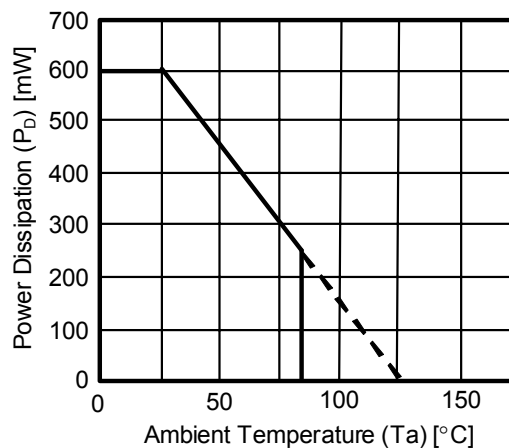

Figure 3 Power Dissipation of Package (When Mounted on Board)

■ Electrical Characteristics

Table 4

(Ta = 25°C unless otherwise specified)

Parameter	Symbol	Conditions	Min.	Typ.	Max.	Unit	Measurement Circuit
Discharge start voltage <sup>*1</sup>	V <sub>CPOUT1</sub>	V <sub>IN</sub> = 0.35 V	V <sub>CPOUT1(S)</sub> - 0.1	V <sub>CPOUT1(S)</sub>	V <sub>CPOUT1(S)</sub> + 0.1	V	1
Discharge stop voltage <sup>*2</sup>	V <sub>CPOUT2</sub>	V <sub>CPOUT1(S)</sub> = 1.8 V	V <sub>CPOUT1</sub> - 0.60	-	V <sub>CPOUT1</sub> - 0.33	V	1
		V <sub>CPOUT1(S)</sub> = 2.0 V	V <sub>CPOUT1</sub> - 0.67	-	V <sub>CPOUT1</sub> - 0.33	V	1
		V <sub>CPOUT1(S)</sub> = 2.2 V	V <sub>CPOUT1</sub> - 0.74	-	V <sub>CPOUT1</sub> - 0.33	V	1
		V <sub>CPOUT1(S)</sub> = 2.4 V	V <sub>CPOUT1</sub> - 0.80	-	V <sub>CPOUT1</sub> - 0.33	V	1
Operating input voltage <sup>*3</sup>	V <sub>IN</sub>	V <sub>CPOUT1(S)</sub> = 1.8 to 2.4 V, Ta = -40 to +85°C	0.35	-	3.0	V	2
		V <sub>CPOUT1(S)</sub> = 1.8, 2.0 V, Ta = -30 to +60°C	0.30	-	3.0	V	2
Oscillation start voltage	V <sub>ST</sub>	Not externally connected, voltage applied to V <sub>IN</sub>	-	-	0.3	V	-
Discharge control switch resistance	R <sub>M1</sub>	V <sub>CPOUT</sub> = 1.8 to 2.4 V, I <sub>OUT</sub> = 3 mA	-	34	100	Ω	3
Discharge start delay time <sup>*4</sup>	t <sub>OUT</sub>	V <sub>IN</sub> = 0.35 V, C <sub>CPOUT</sub> = 10 μF	-	7	25	s	2
Discharge start voltage temperature coefficient	$\frac{\Delta V_{CPOUT1}}{\Delta Ta \cdot V_{CPOUT1}}$	Ta = -40 to +85°C	-	±150	±550	ppm/°C	-
Current consumption during operation	I <sub>SS</sub>	V <sub>IN</sub> = 0.3 V, V <sub>CPOUT</sub> = 0 V	-	0.1	0.5	mA	4
		V <sub>IN</sub> = 0.6 V, V <sub>CPOUT</sub> = 0 V	-	0.5	1.5	mA	4
		V <sub>IN</sub> = 1.0 V, V <sub>CPOUT</sub> = 0 V	-	1.2	3.0	mA	4
Current consumption during shutdown	I <sub>SSS</sub>	V <sub>IN</sub> = 0.3 V, V <sub>CPOUT</sub> = 0 V, V <sub>VM</sub> = 3.0 V	-	-	0.6	μA	5
		V <sub>IN</sub> = 0.6 V, V <sub>CPOUT</sub> = 0 V, V <sub>VM</sub> = 3.0 V	-	-	0.7	μA	5
		V <sub>IN</sub> = 1.0 V, V <sub>CPOUT</sub> = 0 V, V <sub>VM</sub> = 3.0 V	-	-	0.7	μA	5
		V <sub>IN</sub> = 2.0 V, V <sub>CPOUT</sub> = 0 V, V <sub>VM</sub> = 3.0 V	-	-	0.8	μA	5
Shutdown voltage <sup>*5</sup>	V <sub>OFF</sub>	V <sub>IN</sub> = 0.3 V, V <sub>CPOUT</sub> = 0 V	V <sub>OFF(S)</sub> - 0.1	V <sub>OFF(S)</sub>	V <sub>OFF(S)</sub> + 0.1	V	6
Shutdown voltage temperature coefficient	$\frac{\Delta V_{OFF}}{\Delta Ta \cdot V_{OFF}}$	Ta = -40 to +85°C	-	±150	±550	ppm/°C	-
Discharge control switch leak current <sup>*6</sup>	I <sub>LEAK</sub>	V <sub>IN</sub> = V <sub>CPOUT</sub> = 0 V, V <sub>OUT</sub> = V <sub>VM</sub> = 3.0 V	-	-	0.1	μA	7
VM pin input current	I <sub>VM</sub>	V <sub>VM</sub> = 3.0 V	-	1.0	1.9	μA	8
Oscillation frequency	f <sub>OSC</sub>	V <sub>IN</sub> = 0.3 V	-	350	-	kHz	-

- \*1. V<sub>CPOUT1</sub> : Actual discharge start voltage value, V<sub>CPOUT1(S)</sub> : Discharge start voltage setting value
- \*2. Voltage at which discharge to the OUT pin stops
- \*3. Input voltage required to start discharge to the OUT pin from the startup capacitor
- \*4. Delay time from when power is input to the VIN pin until the electric charge of the startup capacitor is discharged to the OUT pin
- \*5. V<sub>OFF</sub> : Actual shutdown voltage value (VM pin voltage value at which shutdown actually occurs)  
 V<sub>OFF(S)</sub> : Shutdown voltage setting value (VM pin voltage setting value at which shutdown occurs)  
 V<sub>OFF(S)</sub> is automatically set to V<sub>CPOUT1(S)</sub> + 0.1 V.
- \*6. Current that flows into the IC from the OUT pin due to the off-leak current of the discharge control switch

**Caution** The voltage that is input to the connected step-up DC-DC converter varies according to the consumption current of the step-up DC-DC converter and the power smoothing capacitor. Set the discharge start voltage based on thorough evaluation including the temperature characteristics under the actual usage conditions.

■ **Measurement Circuits**

1.

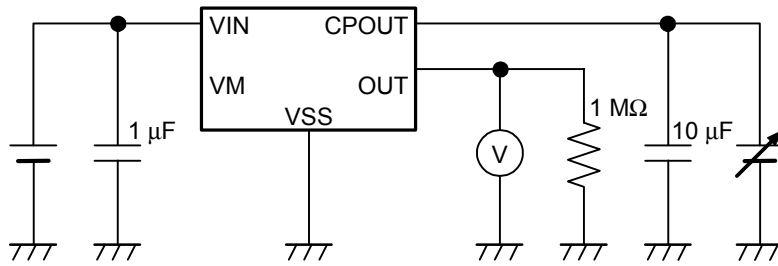

**Figure 4**

2.

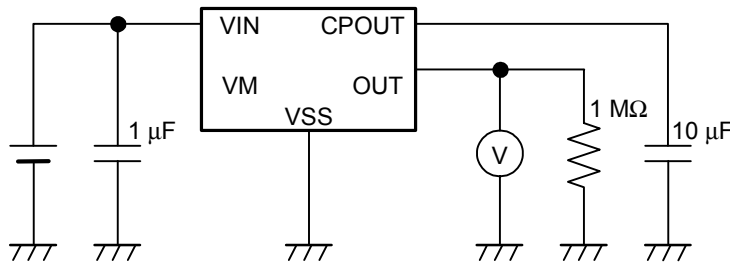

**Figure 5**

3.

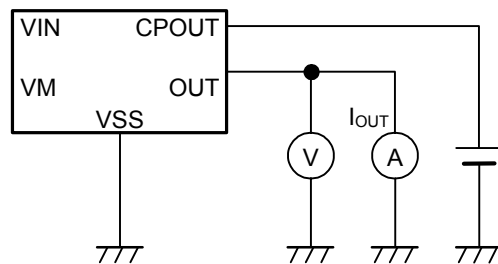

**Figure 6**

4.

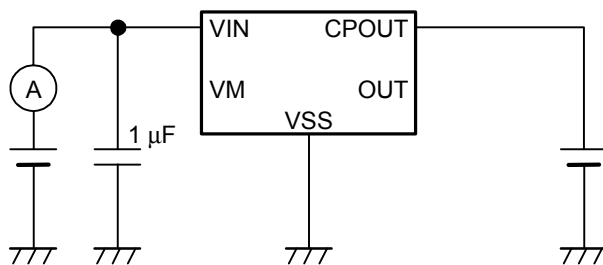

**Figure 7**

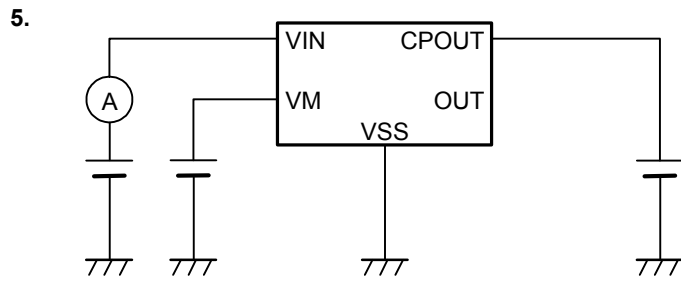

Figure 8

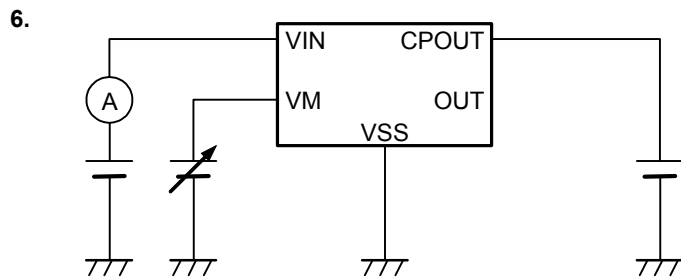

Figure 9

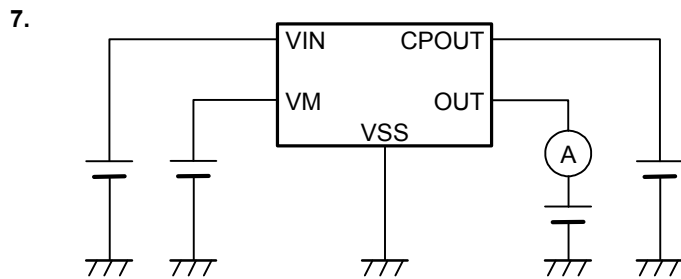

Figure 10

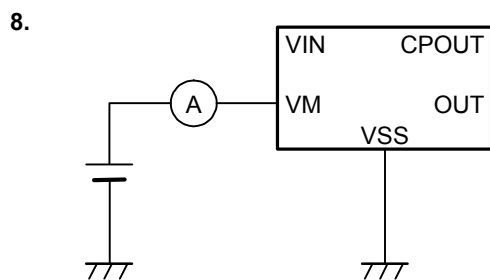

Figure 11

■ **Operation**

1. **Basic Operation : IC with 2.0 V Discharge Start Voltage**

- (1) In the S-882Z Series, when power of 0.3 V or higher is input to the VIN pin, the oscillation circuit starts operation with that power, and the CLK signal is output from the oscillation circuit.
- (2) The charge pump circuit is driven by this CLK signal, and the power of the VIN pin is converted to the stepped up electric power in the charge pump circuit.
- (3) The stepped up electric power output from the charge pump circuit is gradually charged to the startup capacitor ( $C_{CPOUT}$ ) connected to the CPOUT pin and the voltage of the CPOUT pin gradually rises.
- (4) When the CPOUT pin voltage ( $V_{CPOUT}$ ) reaches or exceeds the discharge start voltage ( $V_{CPOUT1}$ ), the output signal of the comparator (COMP1) changes from high level to low. As a result, the discharge control switch (M1), which was off, turns on.
- (5) When M1 switches on, the step up electric power charged to  $C_{CPOUT}$  is discharged from the OUT pin.
- (6) When  $V_{CPOUT}$  declines to the level of the discharge stop voltage ( $V_{CPOUT2}$ ) as the result of the discharge, M1 switches off, and the discharge is stopped.
- (7) When the VM pin voltage ( $V_{VM}$ ) reaches or exceeds the shutdown voltage ( $V_{OFF}$ ), the output signal (EN-) of the comparator (COMP2) changes from low level to high. As a result, the oscillation circuit stops operation and the shutdown state is entered.
- (8) When  $V_{VM}$  does not reach  $V_{OFF}$  or more, the stepped up electric power from the charge pump circuit is recharged to  $C_{CPOUT}$ . (Return to the operation specified in (3).)

**Caution** When stopping the discharge to OUT pin and recharging a startup capacitor ( $C_{CPOUT}$ ),  $C_{CPOUT}$  is needed to be charged until CPOUT pin voltage ( $V_{CPOUT}$ ) is lowered less than discharge stop voltage ( $V_{CPOUT2}$ ). In this case, set the condition as follows:

**Condition: Out pin voltage ( $V_{OUT}$ ) < Discharge stop voltage ( $V_{CPOUT2}$ )**

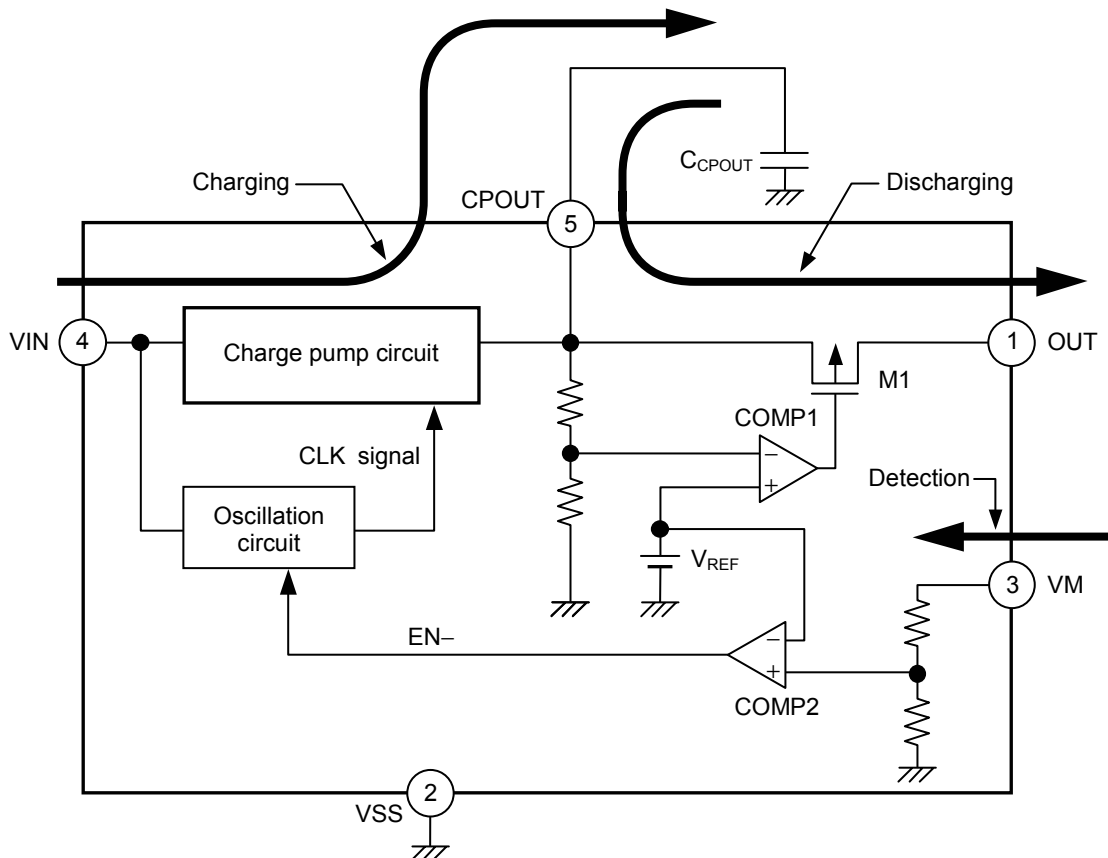
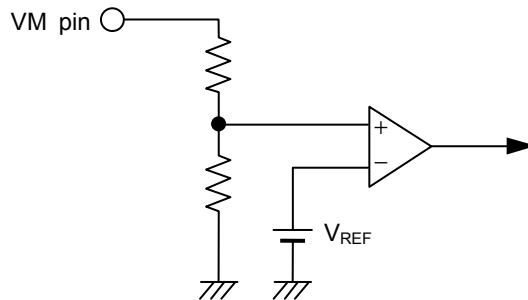

**Figure 12 Operation Diagram**  
 Seiko Instruments Inc.



**2. Step-up DC-DC Converter Output Voltage Monitor Pin (VM Pin)**

When the output voltage of the step-up DC-DC converter to be monitored rises and the VM pin voltage ( $V_{VM}$ ) reaches or exceeds the shutdown voltage ( $V_{OFF}$ ), the shutdown state is entered. When this happens, the internal oscillation circuit stops its operation, so that the charge pump circuit operation stops, and greatly reduces the power consumption. **Figure 13** shows the configuration of the VM pin.



**Figure 13 VM Pin Configuration**

**Table 5**

VM Pin	Internal Circuit
$V_{VM} < V_{OFF}$	Operating
$V_{VM} \geq V_{OFF}$	Shutdown

Set  $V_{VM}$  during shutdown as follows.

$$V_{VM} \geq V_{IN} + 1.0 \text{ V}$$

$$V_{VM} \geq V_{OUT}$$

When  $V_{VM} < V_{IN} + 1.0 \text{ V}$  occurs, the shutdown current consumption increases.

When  $V_{VM} < V_{OUT}$  occurs, the discharge control switch leak current increases.

- Caution1.** When not using the VM pin, be sure to connect it to the VSS pin. If the VM pin is left open, it may cause malfunctions.
- Note that the operation to restart a step-up DC-DC converter does not start when CPOUT pin voltage ( $V_{CPOUT}$ ) exceeds the discharge stop voltage ( $V_{CPOUT2}$ ) even if the power-off state is released. This operation restarts if  $V_{CPOUT}$  is lowered than  $V_{CPOUT2}$  by discharge of a start-up capacitor ( $C_{CPOUT}$ ).**

■ **Selection of Product and Startup Capacitor (C<sub>CP<sub>OUT</sub></sub>)**

To reliably start up the step-up DC-DC converter, in the S-882Z Series, select the discharge start voltage value (V<sub>CP<sub>OUT1</sub></sub>) and the capacitance value of the external startup capacitor (C<sub>CP<sub>OUT</sub></sub>) according to the step-up DC-DC converter to be started, its external parts, and the output load.

Generally, an output smoothing capacitor with a large capacitance value and an output load are connected to the output pin of the step-up DC-DC converter. Therefore, to start up the step-up DC-DC converter thus connected, it is necessary to select a large capacitance value for the startup capacitor.

As a reference, the following shows an example that a Schottky diode (SD1) is added between the output pin (OUT) and the power supply pin (VDD) of the step-up DC-DC converter to be started up in the S-882Z Series (refer to **Figure 14**). As a result, it is possible to start up the step-up DC-DC converter by the capacitor with a small value.

C<sub>VDD</sub> in **Figure 14** is the power supply smoothing capacitor of the step-up DC-DC converter.

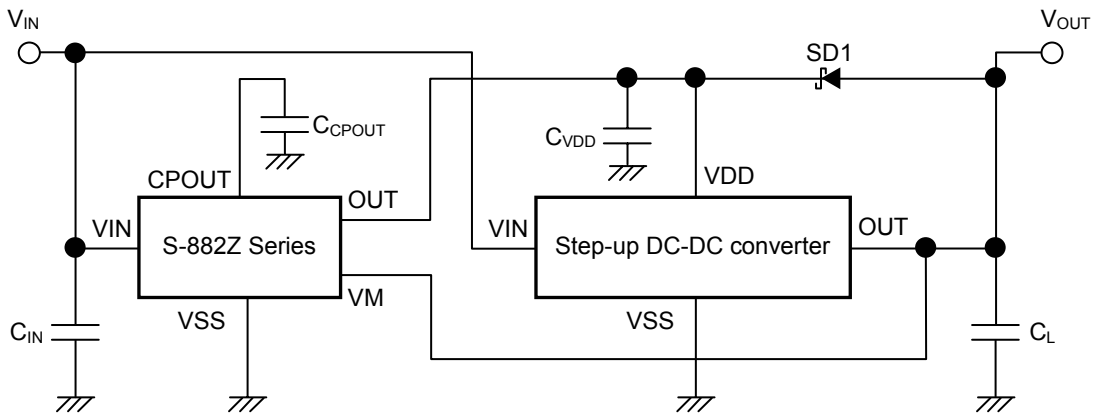

**Figure 14 Connection Diagram (Reference)**

The selection method for V<sub>CP<sub>OUT1</sub></sub> and C<sub>CP<sub>OUT</sub></sub> when the reference connection shown in **Figure 14** has been performed is described below.

Select V<sub>CP<sub>OUT1</sub></sub> and C<sub>CP<sub>OUT</sub></sub> so that they satisfy the following conditional expression.

$$\left( \frac{V_{CP_{OUT1}} \cdot C_{CP_{OUT}}}{C_{CP_{OUT}} + C_{VDD}} - 0.1 \cdot I_{VDD} - V_{DDL} \right) \cdot (C_{CP_{OUT}} + C_{VDD}) > 2t_s \cdot I_{VDD}$$

$$V_{CP_{OUT1}} > V_{DDL} + 0.2 V$$

$$C_{CP_{OUT}} > 10C_{VDD}$$

V<sub>CP<sub>OUT1</sub></sub> : Discharge start voltage value of S-882Z Series (unit : V)

C<sub>CP<sub>OUT</sub></sub> : Capacitance value of startup capacitor (unit : μF)

C<sub>VDD</sub> : Capacitance value of power smoothing capacitor for step-up DC-DC converter (unit : μF)

I<sub>VDD</sub> : Consumption current value of step-up DC-DC converter (unit : mA)

V<sub>DDL</sub> : Minimum operation voltage of step-up DC-DC converter (unit : V)

t<sub>s</sub> : Step-up DC-DC converter startup time ≅ Soft start time (unit : ms)

If the Schottky diode (SD1) has a large reverse current or if a pull-down resistor is added to the OUT pin of the S-882Z Series, add the current value generated from these to the current consumption ( $I_{VDD}$ ) of the step-up DC-DC converter.

Moreover, if a Schottky diode is added between the OUT pin of the S-882Z Series and the power supply pin (VDD pin) of the step-up DC-DC converter, set  $V_{CPOUT1}$  so that it is higher by the amount corresponding to the forward drop voltage ( $V_F$ ) of the added Schottky diode in comparison to the discharge start voltage value ( $V_{CPOUT1}$ ) obtained with the above described conditional expression.

- Cautions 1.** The S-882Z Series can start up the step-up DC-DC converter more reliably as the discharge start voltage value ( $V_{CPOUT1}$ ) and the startup capacitor value ( $C_{CPOUT}$ ) are larger. However, note that the time from when the input power is input until the step-up DC-DC converter starts becomes longer in this case.
- 2.** In the S-882Z Series,  $C_{CPOUT}$  can be more lowered as  $V_{CPOUT1}$  is higher, but note that if  $V_{CPOUT1} \geq 2.2$  V, the minimum value of the operation input voltage (the minimum input voltage value required for power to be output from the OUT pin of the S-882Z Series) rises from 0.3 V to 0.35 V (refer to Table 6).

**Table 6**

Discharge Start Voltage Value	Minimum Operation Input Voltage Value	Temperature Range
1.8, 2.0 V	0.3 V	-30 to +60°C
1.8 to 2.4 V	0.35 V	-40 to +85°C

**Caution** The above connection diagram and constant will not guarantee successful operation. Perform thorough evaluation using the actual application to set the constant.

■ **Standard Circuit**

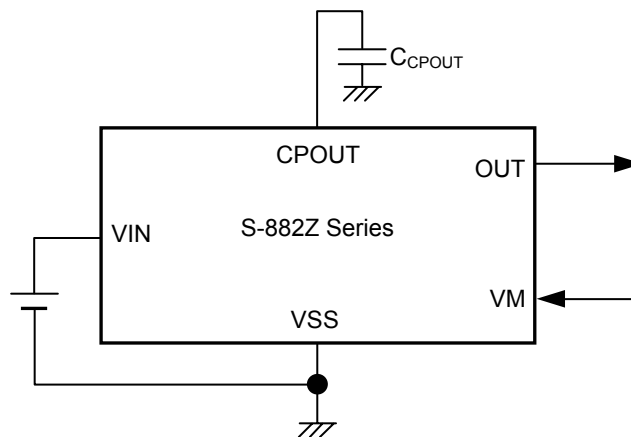

**Figure 15**

**Caution** The above connection diagram and constant will not guarantee successful operation. Perform thorough evaluation using the actual application to set the constant.

■ **Example of Connection with Step-up DC-DC Converter**

The following are the connection examples based on the set condition.  
 The symbols used in the connection diagram are described in **Table 7** below.

Table 7	
Symbol	Description
SD1	A Schottky diode for preventing a voltage decline in the VDD pin due to output capacitor $C_L$ at step-up DC-DC converter startup.
$C_{VDD}$	The power smoothing capacitor of the step-up DC-DC converter. Set the capacitance value so that $C_{VDD} \leq C_{CPOUT} \times 0.1$ .
SD2, $R_{OUT}$	A Schottky diode and pull-down resistor to prevent the OUT pin voltage of the S-882Z Series from exceeding the absolute maximum rated voltage.
$R_1, R_2$	Bleeder resistors to prevent the VM pin voltage of the S-882Z Series from exceeding the absolute maximum rated voltage.

1.  $V_{OUT} \leq 3.0\text{ V}$ ,  $C_L \leq C_{CPOUT} \times 0.1$ , no load

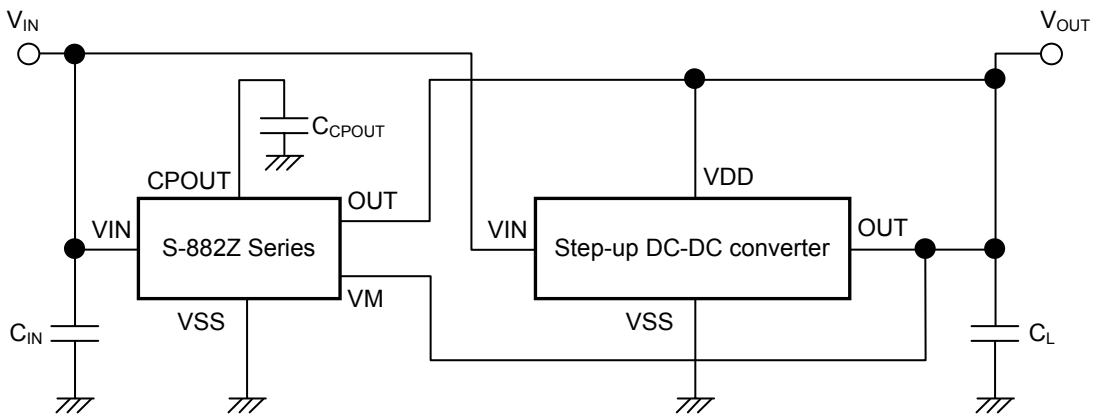

Figure 16

2.  $V_{OUT} \leq 3.0\text{ V}$ ,  $C_L > C_{CPOUT} \times 0.1$

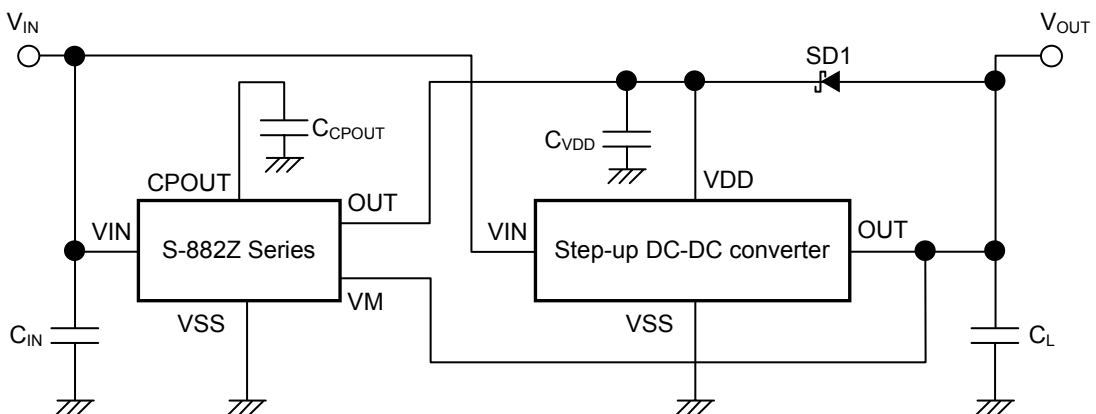

Figure 17

3.  $V_{OUT} > 3.0\text{ V}$ ,  $C_L \leq C_{CPOUT} \times 0.1$ , no load

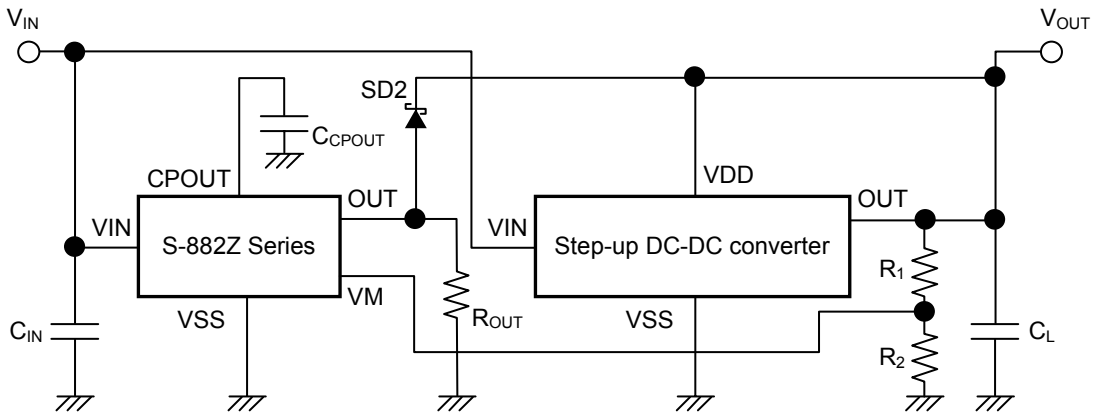

Figure 18

4.  $V_{OUT} > 3.0\text{ V}$ ,  $C_L > C_{CPOUT} \times 0.1$

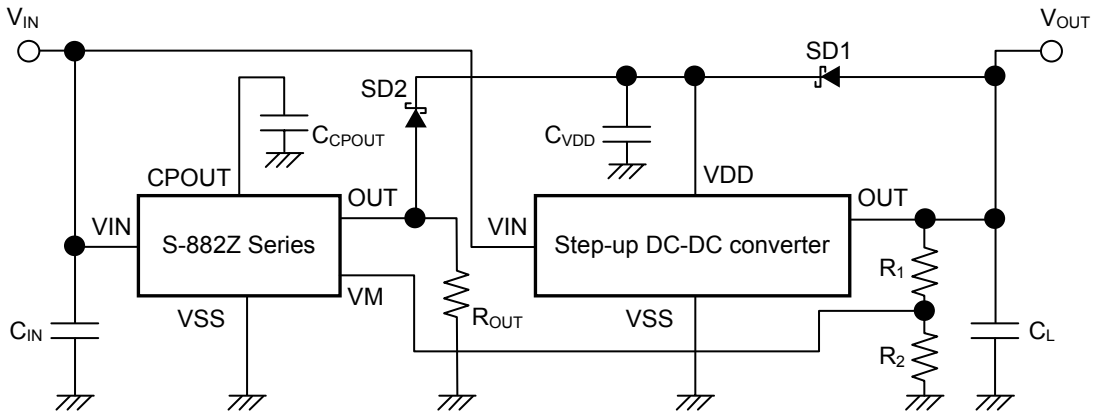

Figure 19

**Caution** The above connection diagram and constant will not guarantee successful operation. Perform thorough evaluation using the actual application to set the constant.

## ■ Precautions

- If the consumption current ( $I_{SSS}$ ) during shutdown needs to be kept at  $0.8 \mu\text{A}$  or lower, set the VM pin voltage ( $V_{VM}$ ) so that conditions (1) and (2) below are satisfied.

$$(1) V_{VM} \geq V_{OFF}$$

$$(2) V_{IN} + 1.0 \text{ V} \leq V_{VM} \leq 3.0 \text{ V}$$

- If the discharge start voltage ( $V_{CPOUT1}$ ) of this IC is lower than the operating voltage of the step-up DC-DC converter to be started, the step-up DC-DC converter may not start up. When selecting products, fully check them using an actually mounted model. (Refer to ■ **Selection of Product and Startup Capacitor ( $C_{CPOUT}$ )**.)
- Select a capacitor with a sufficiently large capacitance for the startup capacitor. In the case of a capacitor with insufficient capacitance, the step-up DC-DC converter may not start up. When selecting products, fully check them using an actually mounted model. (Refer to ■ **Selection of Product and Startup Capacitor ( $C_{CPOUT}$ )**.)
- The discharge start delay time ( $t_{OUT}$ ) is longer according to conditions (1), (2), and (3) below. Also note it is further longer when these conditions are combined.
  - (1) The operating input voltage ( $V_{IN}$ ) is low.
  - (2) The discharge start voltage ( $V_{CPOUT1}$ ) is high.
  - (3) The startup capacitor value ( $C_{CPOUT}$ ) is large.
- When stopping the discharge to OUT pin and recharging a startup capacitor ( $C_{CPOUT}$ ),  $C_{CPOUT}$  is needed to be charged until CPOUT pin voltage ( $V_{CPOUT}$ ) is lowered less than discharge stop voltage ( $V_{CPOUT2}$ ). In this case, set the condition as follows:
  - Condition: OUT pin voltage ( $V_{OUT}$ ) < Discharge stop voltage ( $V_{CPOUT2}$ )
- Note that the operation to restart a step-up DC-DC converter does not start when CPOUT pin voltage ( $V_{CPOUT}$ ) exceeds the discharge stop voltage ( $V_{CPOUT2}$ ) even if the power-off state is released. This operation restarts if  $V_{CPOUT}$  is lowered than  $V_{CPOUT2}$  by discharge of a start-up capacitor ( $C_{CPOUT}$ ).
- When designing for mass production using an application circuit described herein, the product deviation and temperature characteristics should be taken into consideration. SII shall not bear any responsibility for the products on the circuits described herein.
- Do not apply an electrostatic discharge to this IC that exceeds the performance ratings of the built-in electrostatic protection circuit.
- SII claims no responsibility for any disputes arising out of or in connection with any infringement by products including this IC of patents owned by a third party.

■ Characteristics (Typical Data)

1. Discharge Start Voltage ( $V_{CPOUT1}$ ), Discharge Stop Voltage ( $V_{CPOUT2}$ ) vs. Input Voltage ( $V_{IN}$ )

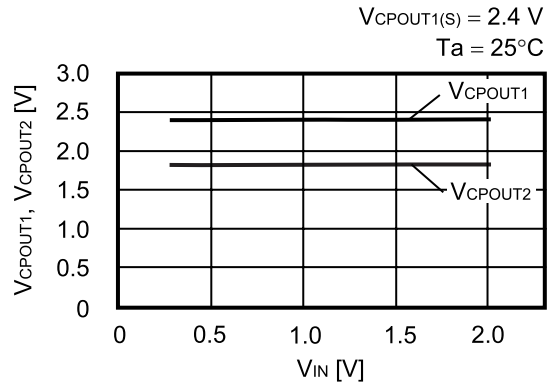
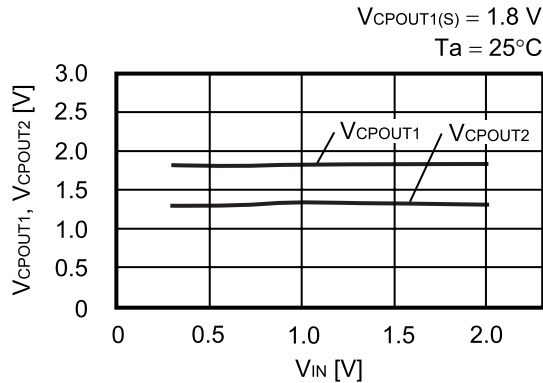

2. Discharge Start Voltage ( $V_{CPOUT1}$ ), Discharge Stop Voltage ( $V_{CPOUT2}$ ) vs. Temperature ( $T_a$ )

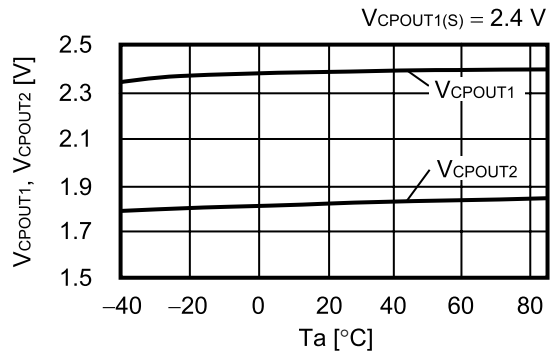
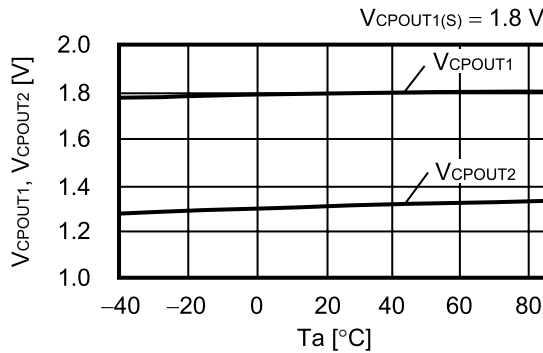

3. Discharge Control Switch Resistance ( $R_{M1}$ ) vs. CPOUT Pin Voltage ( $V_{CPOUT}$ )

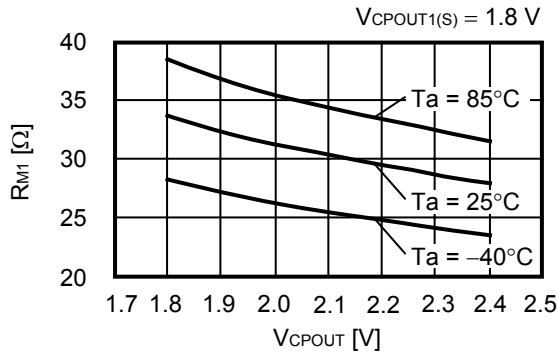

4. Discharge Start Delay Time ( $t_{OUT}$ ) vs. Input Voltage ( $V_{IN}$ )

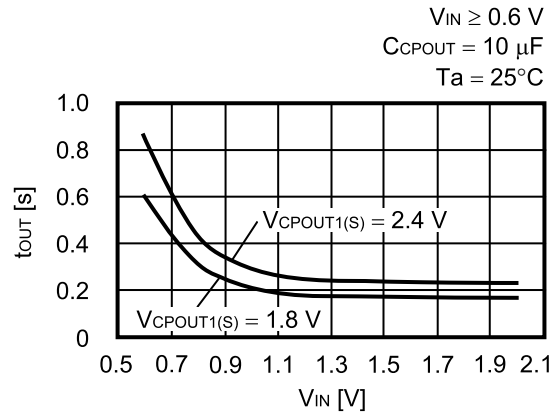
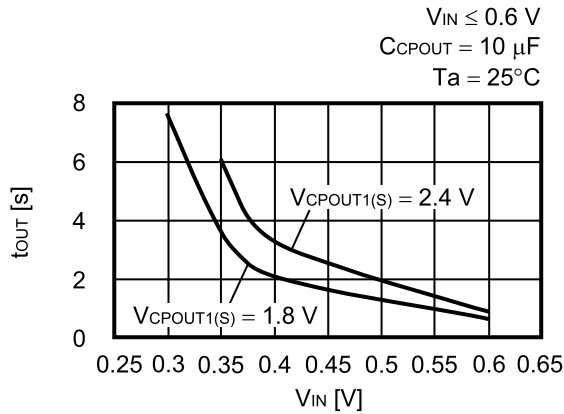

**5. Discharge Start Delay Time ( $t_{OUT}$ ) vs. Startup Capacitor Capacitance Value ( $C_{CPOUT}$ )**

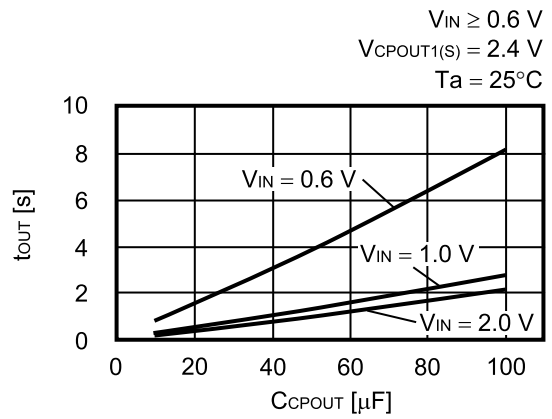
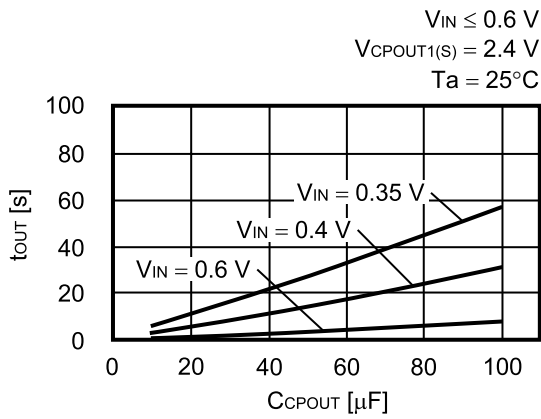
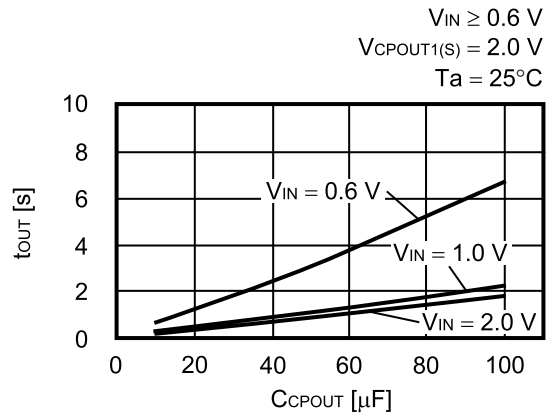
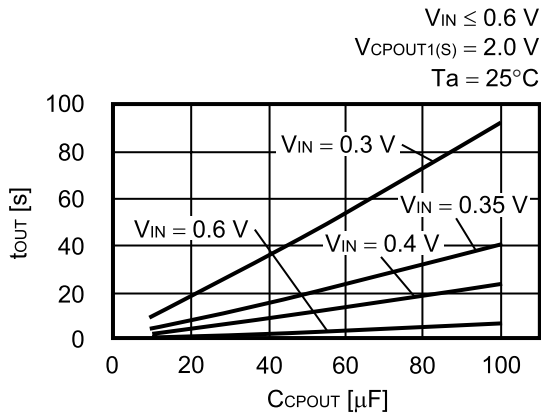

**6. Discharge Start Delay Time ( $t_{OUT}$ ) vs. Temperature ( $T_a$ )**

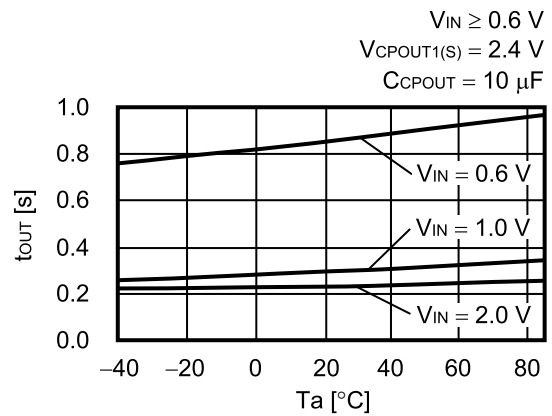
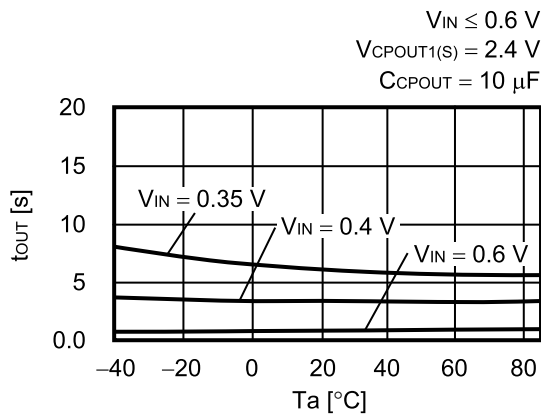
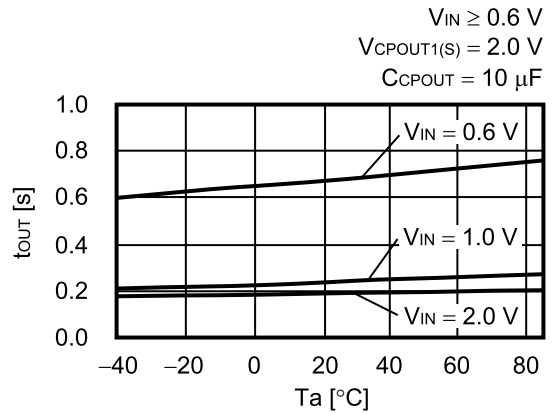
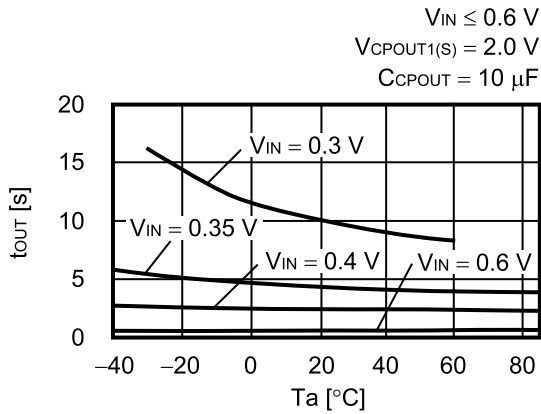



**7. Current Consumption During Operation ( $I_{SS}$ ) vs. Input Voltage ( $V_{IN}$ )**

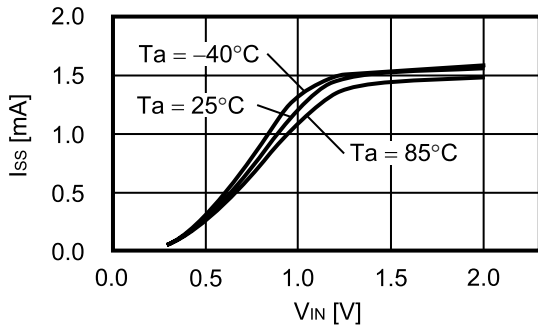

**8. Current Consumption During Shutdown ( $I_{SSS}$ ) vs. Input Voltage ( $V_{IN}$ )**

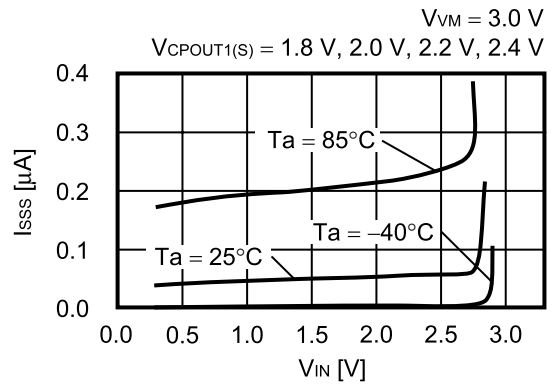
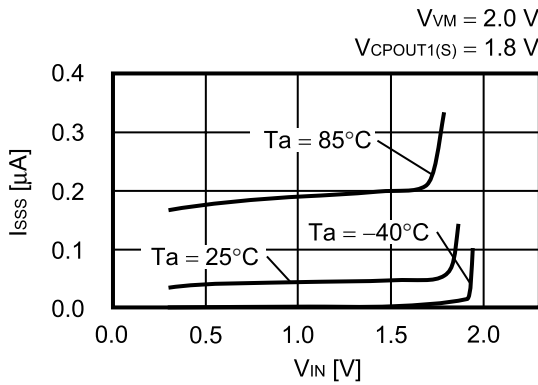

**9. Shutdown Voltage ( $V_{OFF}$ ) vs. Input Voltage ( $V_{IN}$ )**

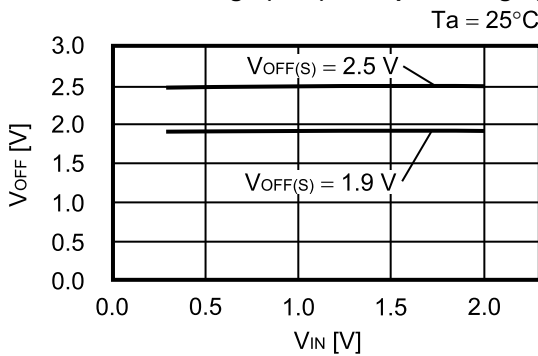

**10. Shutdown Voltage ( $V_{OFF}$ ) vs. Temperature ( $T_a$ )**

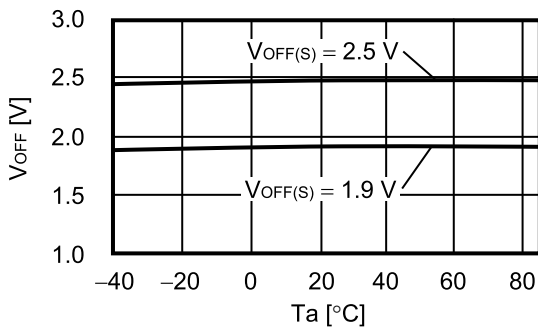

**11. Discharge Control Switch Leak Current ( $I_{LEAK}$ ) vs. Input Voltage ( $V_{IN}$ )**

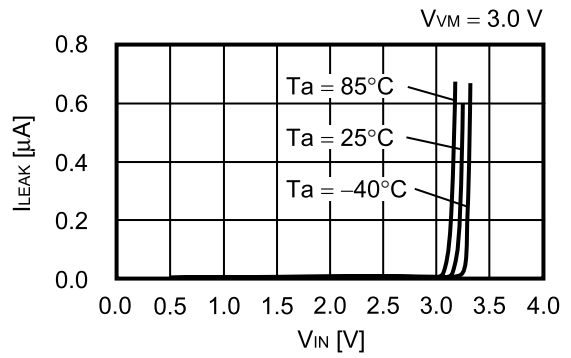
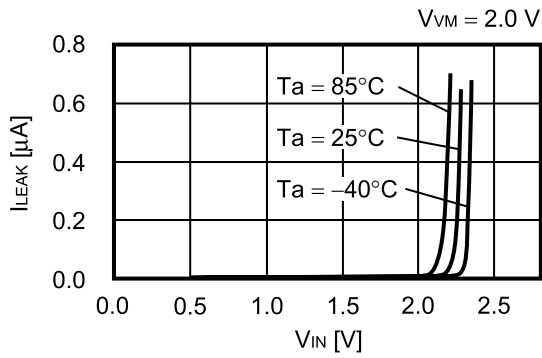

**12. VM Pin Input Current ( $I_{VM}$ ) vs. VM Pin Voltage ( $V_{VM}$ )**

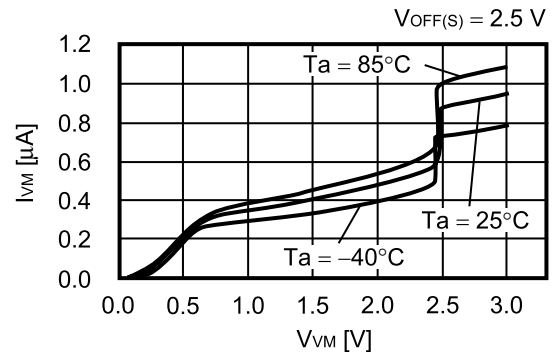
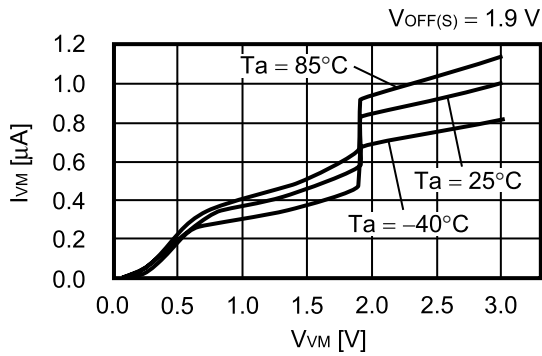

**13. Oscillation Frequency ( $f_{OSC}$ ) vs. Input Voltage ( $V_{IN}$ )**

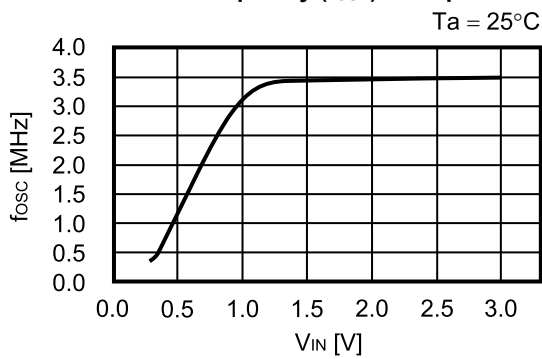

■ Application Circuit Example

Figure 20 shows an application circuit example with targeted values of  $V_{IN} = 0.3\text{ V}$ ,  $V_{OUT} = 3.0\text{ V}$ , and  $I_{OUT} = 1\text{ mA}$ .

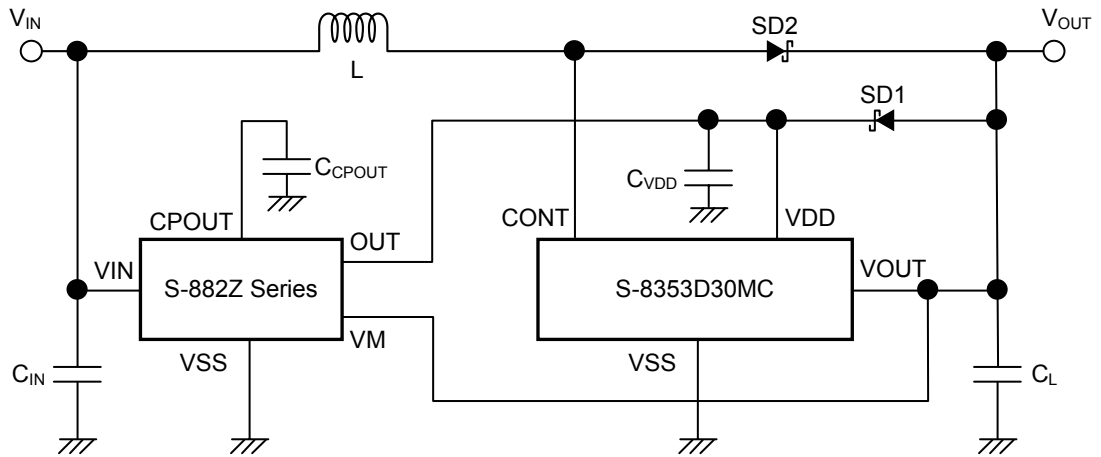

Figure 20

Table 8

Part Name	Symbol	Manufacturer	Part No.
S-882Z Series	–	Seiko Instruments Inc.	S-882Z20-M5T1G (Discharge start voltage value setting : 2.0 V)
Step-up DC-DC converter	–	Seiko Instruments Inc.	S-8353D30MC (Output voltage setting : 3.0 V)
Inductor	L	Sumida Corporation	CDRH5D18-101 (100 $\mu\text{H}$ )
Schottky diode	SD1, SD2	Rohm Co., Ltd.	RB551V-30
Startup capacitor	$C_{CPOUT}$	–	10 $\mu\text{F}$ (ceramic type)
Input capacitor	$C_{IN}$	–	47 $\mu\text{F}$
Output capacitor	$C_L$	–	33 $\mu\text{F}$ (ESR > 50 $\text{m}\Omega$ )
Power smoothing capacitor	$C_{VDD}$	–	1 $\mu\text{F}$ (ceramic type)

**Caution** The above connection diagram and constant will not guarantee successful operation. Perform thorough evaluation using the actual application to set the constant.

■ **Marking Specifications**

(1) SOT-23-5

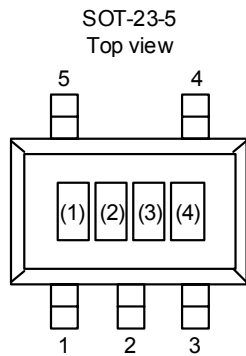

(1) to (3) : Product code (Refer to **Product Name vs. Product Code.**)  
 (4) : Lot number

**Product Name vs. Product Code**

Product Name	Product Code		
	(1)	(2)	(3)
S-882Z18-M5T1G	Q	Y	A
S-882Z20-M5T1G	Q	Y	B
S-882Z22-M5T1G	Q	Y	C
S-882Z24-M5T1G	Q	Y	D

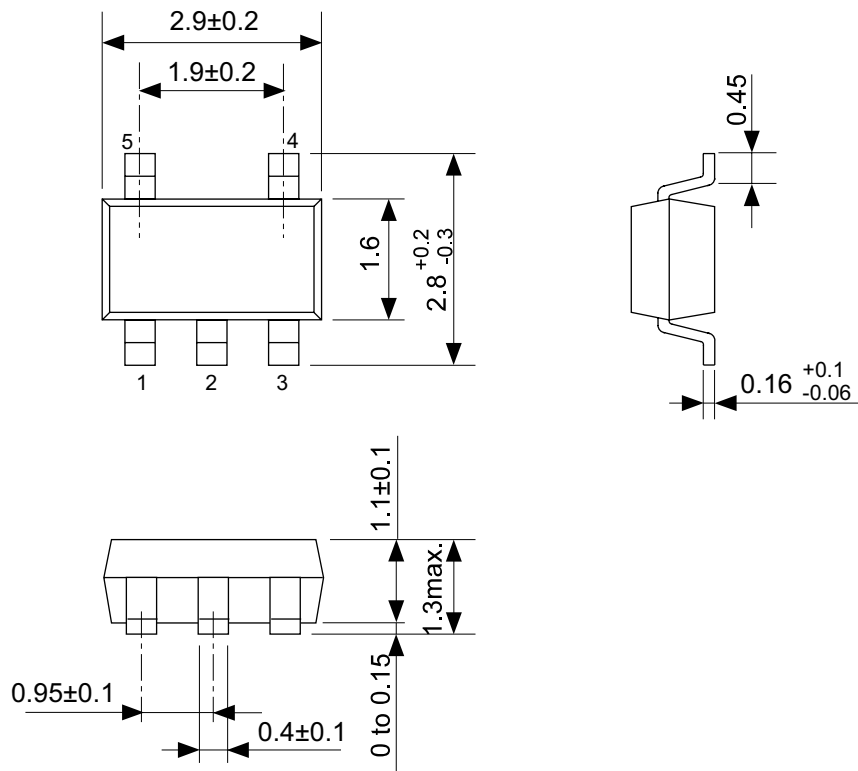

No. MP005-A-P-SD-1.2

TITLE	SOT235-A-PKG Dimensions
No.	MP005-A-P-SD-1.2
SCALE	
UNIT	mm
Seiko Instruments Inc.	

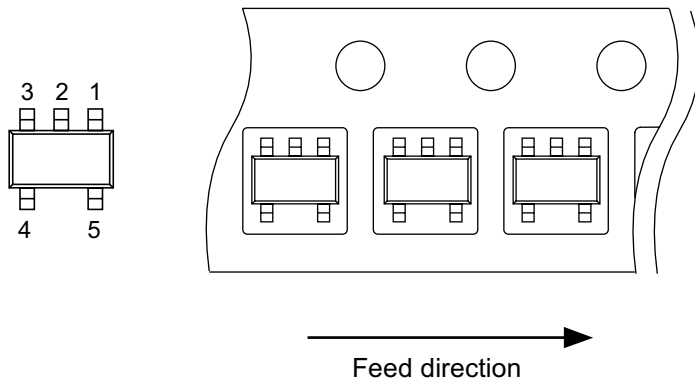
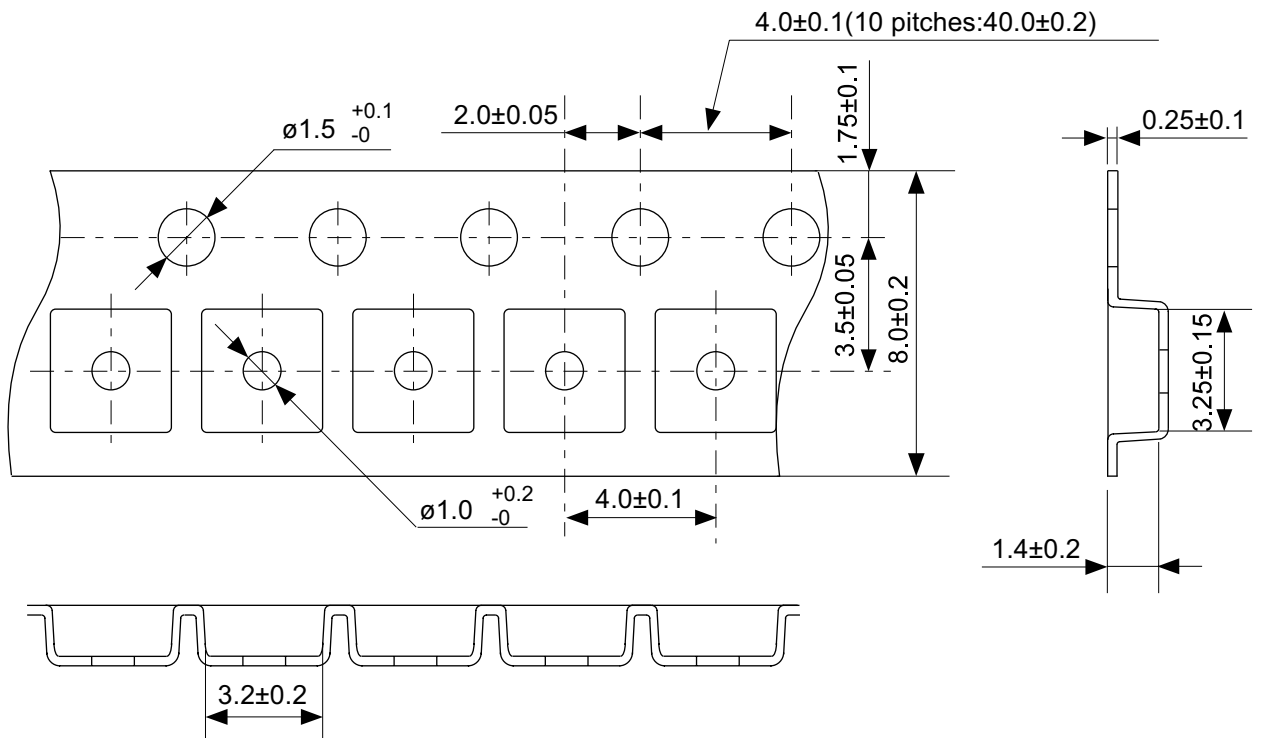

No. MP005-A-C-SD-2.1

TITLE	SOT235-A-Carrier Tape
No.	MP005-A-C-SD-2.1
SCALE	
UNIT	mm
Seiko Instruments Inc.	

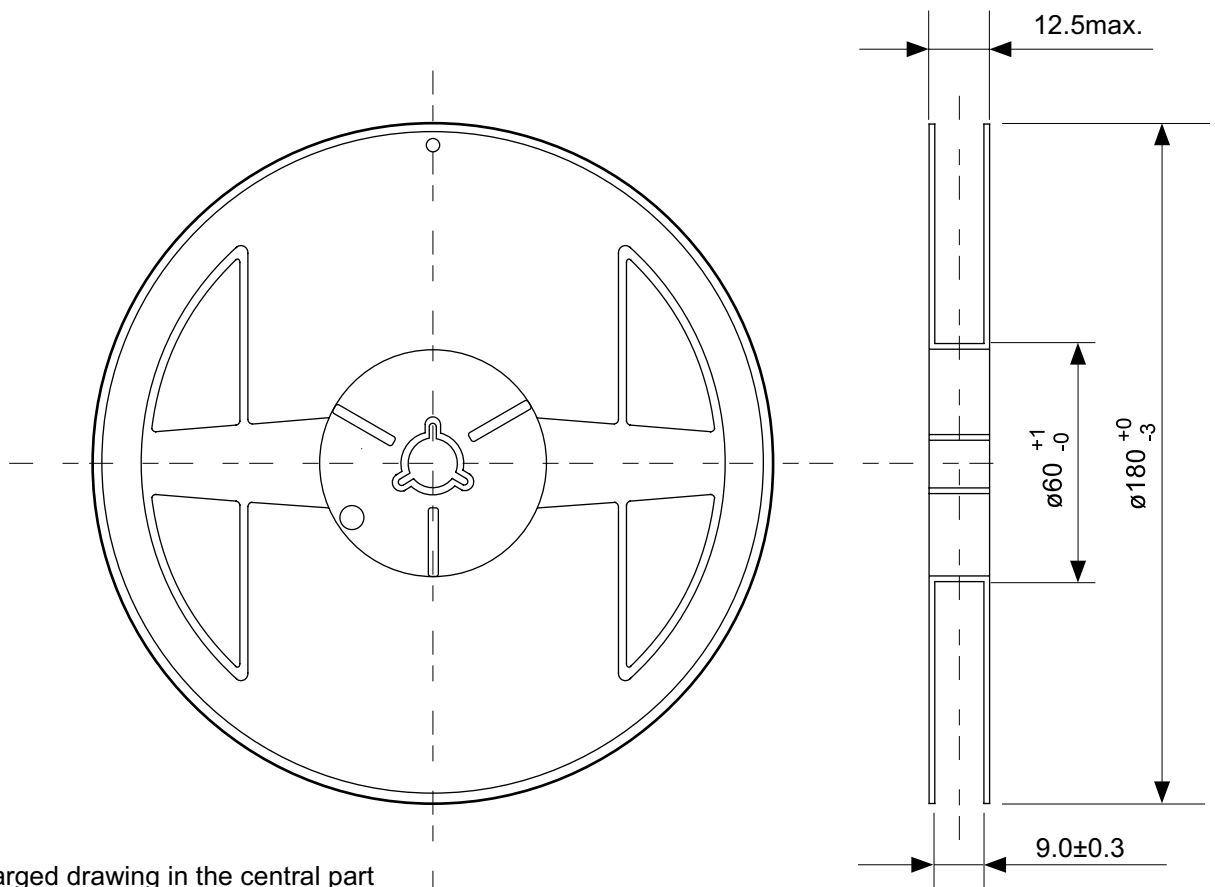

Enlarged drawing in the central part

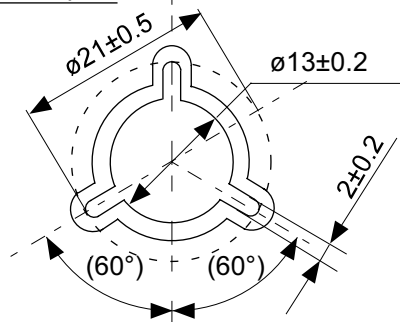

No. MP005-A-R-SD-1.1

TITLE	SOT235-A-Reel		
No.	MP005-A-R-SD-1.1		
SCALE		QTY.	3,000
UNIT	mm		
Seiko Instruments Inc.			

- The information described herein is subject to change without notice.
- Seiko Instruments Inc. is not responsible for any problems caused by circuits or diagrams described herein whose related industrial properties, patents, or other rights belong to third parties. The application circuit examples explain typical applications of the products, and do not guarantee the success of any specific mass-production design.
- When the products described herein are regulated products subject to the Wassenaar Arrangement or other agreements, they may not be exported without authorization from the appropriate governmental authority.
- Use of the information described herein for other purposes and/or reproduction or copying without the express permission of Seiko Instruments Inc. is strictly prohibited.
- The products described herein cannot be used as part of any device or equipment affecting the human body, such as exercise equipment, medical equipment, security systems, gas equipment, or any apparatus installed in airplanes and other vehicles, without prior written permission of Seiko Instruments Inc.
- Although Seiko Instruments Inc. exerts the greatest possible effort to ensure high quality and reliability, the failure or malfunction of semiconductor products may occur. The user of these products should therefore give thorough consideration to safety design, including redundancy, fire-prevention measures, and malfunction prevention, to prevent any accidents, fires, or community damage that may ensue.