

TML-3WRG

FEATURES

- ※ Compact size
- ※ Bi-color LED light
- ※ Sharp click feeling

APPLICATION

- ※ Testing equipment
- ※ Industrial device
- ※ Automation

SPECIFICATION

Contact Rating	50mA, 12V DC
Contact Resistance	100mΩ max.
Insulation Resistance	100MΩ min. 500V DC
Dielectric Strength	250V AC/1 minute
Operating Force	160+80/-30gf
Travel	0.2mm
Operating Life	50,000 cycles
Operating Temp.	-20°C ~ +70°C
Storage Temp.	-30°C ~ +80°C

CIRCUIT

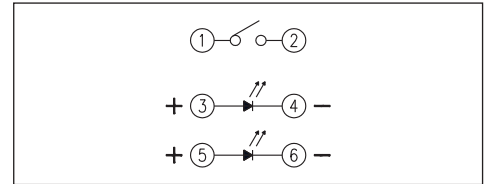

PACKAGE

<Tape & Reel>
3000 pcs.

HOW TO ORDER

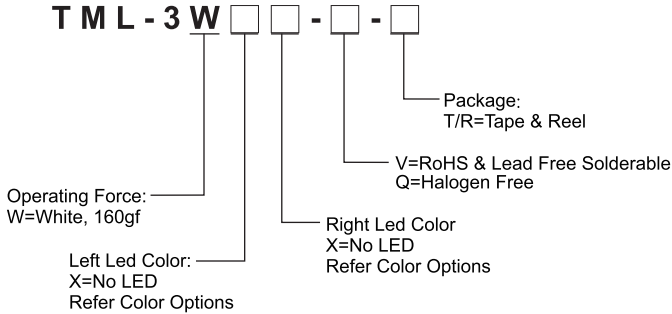

TML-3

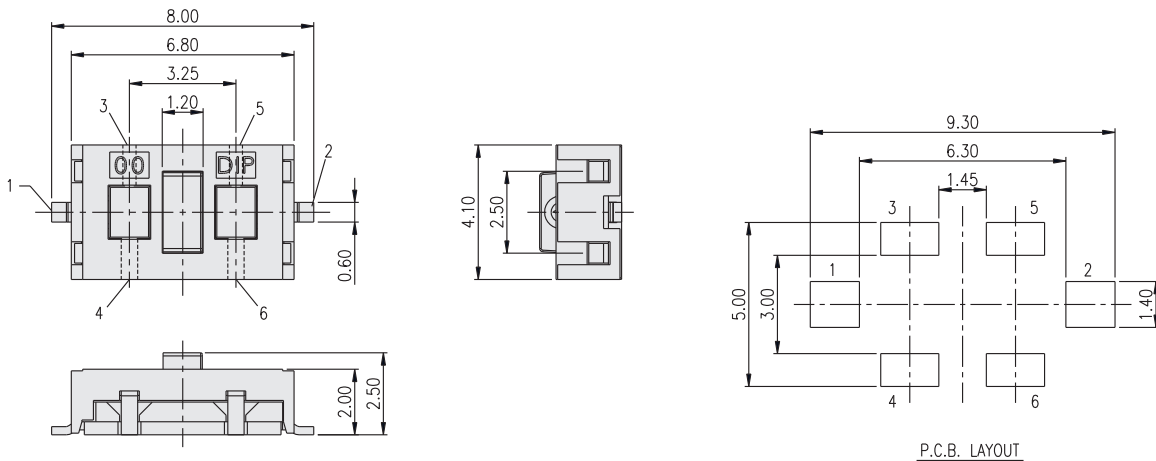

LED Color Options:

Part No.	Color	Dominant Wavelength λ_p Typ.(nm)	Luminous Intensity I_v (mcd)	Forward Voltage V_f (V)		View Angle $2\cdot\theta_{1/2}$ (Degree)
			Typ.	Typ.	Max.	
B	Blue	470	70	3.0	3.6	140°
G	Yellow Green	570	30	2.0	2.3	
O	Yellow	590	60	2.0	2.3	
A	Soft Orange	605	50	2.0	2.3	
R	Red	630	60	2.0	2.3	
W	Cold White	X:0.26 / Y:0.23	350	3.0	3.6	