

Plastic small outline package; 5 leads; body width 1.5 mm

SOT23-5

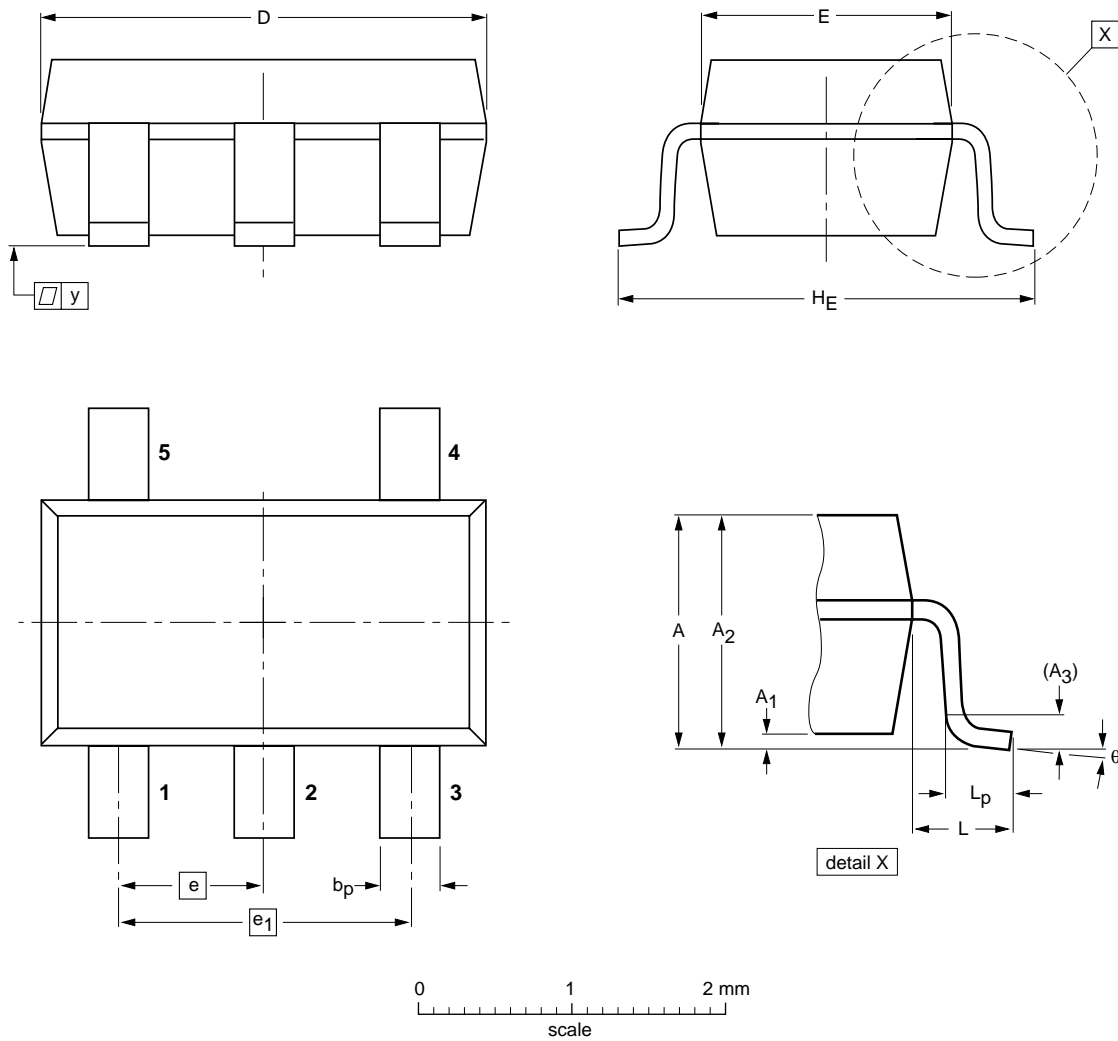

DIMENSIONS (mm are the original dimensions)

UNIT	A max.	A ₁	A ₂	A ₃	b _p	c	D ⁽¹⁾	E ⁽¹⁾	e	e ₁	H _E	L	L _p	y	θ
mm	1.35	0.15 0.05	1.2 1.0	0.025	0.55 0.41	0.22 0.08	3.1 2.7	3.0 2.7	1.7 1.5	1.90	3.0 2.6	0.6	0.55 0.35	0.1	8° 0°

Note

1. Plastic or metal protrusions of 0.25 mm maximum per side are not included.

OUTLINE VERSION	REFERENCES				EUROPEAN PROJECTION	ISSUE DATE
	IEC	JEDEC	JEITA			
SOT23-5		MO-178				02-10-31